

[www.solcopyroelec.co.uk](http://www.solcopyroelec.co.uk)

# COMMERCIAL

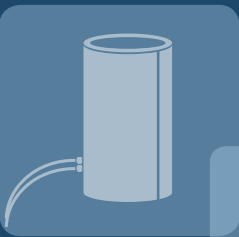
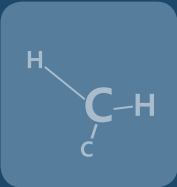
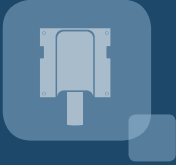
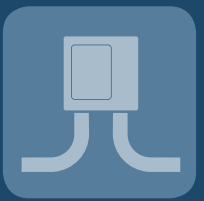

BEST QUALITY AND PERFORMANCE

# SOLCO.

Advanced Trace Heating Solutions

SOLCO

## **SOLCO BUSINESS INNOVATION**

Solco continuously evolves to provide clients with customised engineering design services, backed by comprehensive technical support. We ensure optimal system performance and reliable maintenance of all installed products and solutions.

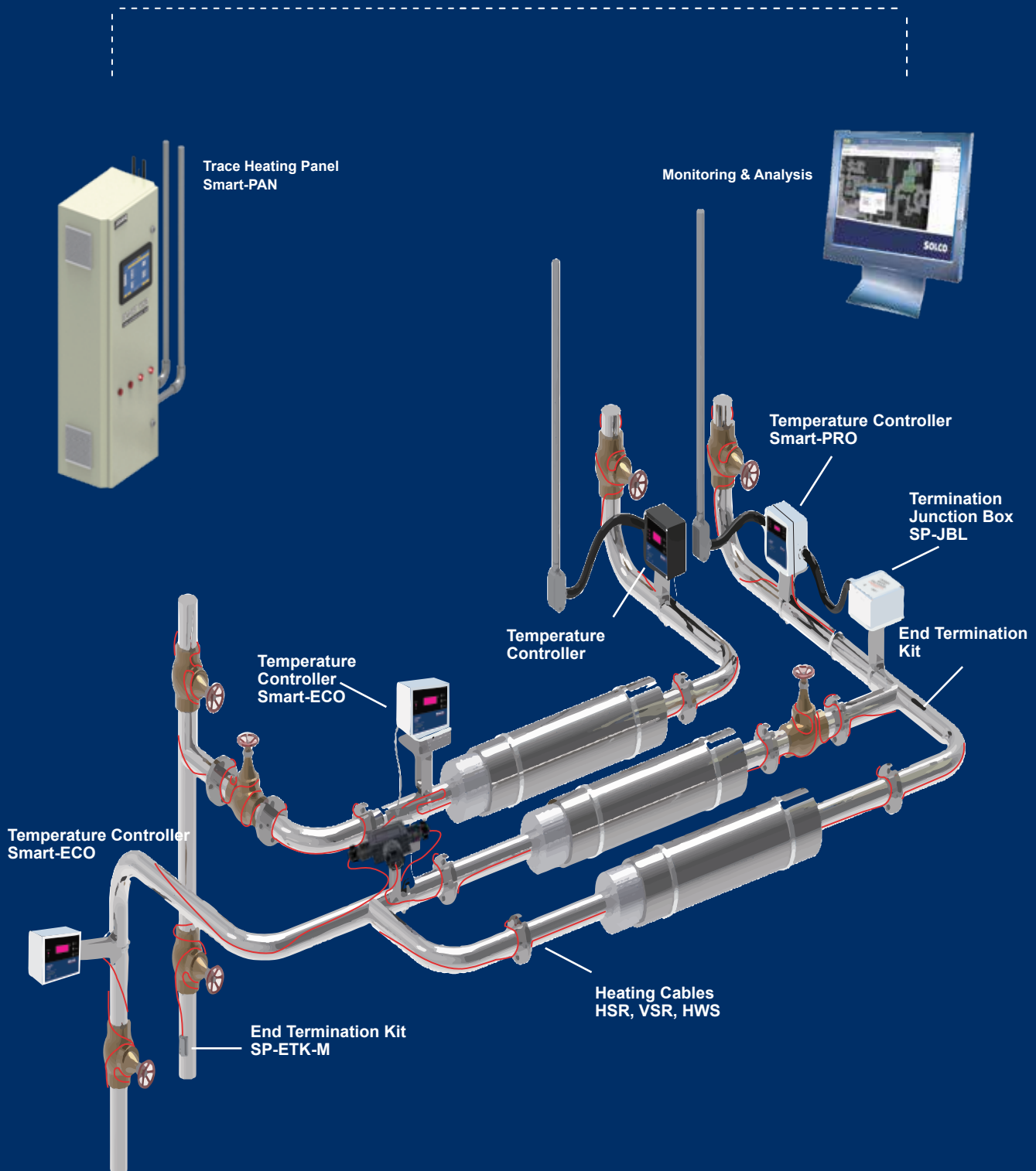



# SOLCO

Provides the most advanced commercial trace heating solutions





## Safety

---

- Certified trace heating cable systems
- Advanced circuit monitoring with performance trend analysis
- Proactive maintenance strategies to minimise costly downtime



## Reliability

---

- Over 27 years of experience in trace heating solutions
- Proven performance and durability of products
- Trusted by major global corporations
- International certifications and approvals
- Expert installation and commissioning services through accredited partners



## Economy

---

- Eliminates production downtime
- Identifies and eliminates hidden energy losses in trace heating circuits
- Achieves energy savings of up to 70%



## Ergonomics

---

- Intelligent monitoring and control options
- Automated design system for trace heating applications
- Simplified installation with advanced termination components

# APPLICATIONS

## Freeze Protection

Pipes in unheated areas risk freezing—even with insulation. A 25mm pipe with 25mm insulation can freeze within an hour at  $-10^{\circ}\text{C}$ . Steam tracing introduces corrosion risks. Solco's electric trace heating with self-regulating cables offers reliable, energy-efficient protection against burst pipes and costly downtime.



## Temp Maintenance / Construction Industry

Pipes carrying hot water and fuel oils must be trace heated, in the case of oils, to prevent clogging or solidification. Insulation alone is not enough. For example, Heavy fuel oil needs to stay above  $60^{\circ}\text{C}$ . Solco's low-power self-regulating cables provide safe, efficient, and maintenance-free temperature control.



## Roof & Gutter Tracing

Similar to ground snow melting, roof and gutter areas benefit from trace heating to prevent snow buildup, ice dams, and drainage blockages. Solco's energy-efficient self-regulating cables maintain clear flow paths and protect building structures throughout the winter, offering a cost-effective, low-maintenance solution for snow and ice management.



### **Concrete Curing**

Proper curing temperatures are critical for concrete strength. In cold climates, delays are common. Traditional heating cables pose fire risks when embedded in insulation. Solco's self-regulating heating cables offer a safe, efficient alternative for consistent curing performance.



### **Snow Melting**

Trace heating is ideal for snow melting and de-icing outdoor surfaces. Snow melting requires  $\sim 300 \text{ W/m}^2$ ; ice prevention needs  $\sim 150 \text{ W/m}^2$  or less. Solco's self-regulating systems with smart controls cut operating costs by up to 80% while ensuring reliable winter protection.



### **Icicle Prevention / Bridge Safety**

Snow on tall structures like bridges and roofs can melt from sunlight or radiant heat, then refreeze in shaded areas, forming hazardous icicles. Solco's IcSR self-regulating cable keeps surface temperatures above  $10^\circ\text{C}$  in these areas, preventing ice formation and enhancing safety for pedestrians and vehicles.



For more information or tailored solutions, please contact Solco.

# TECHNICAL SPECIFICATIONS

## Electrical Trace Heating

### BUILDING SERVICES - COMMERCIAL MARKET SECTOR

It is important to stress that all electrical trace heating systems which are designed, supplied, installed, tested and commissioned within the building services / commercial market sector MUST comply with the following European Norm standard:

#### BS EN 62395-1:2013

“Electrical resistance trace heating systems for industrial and commercial applications (non-hazardous areas) – general & testing requirements”

#### BS EN 62395-2:2013

“Electrical resistance trace heating systems for industrial and commercial applications (non-hazardous areas) – application guide for system design, installation & maintenance”

1

### Primary applications within the Building Services market

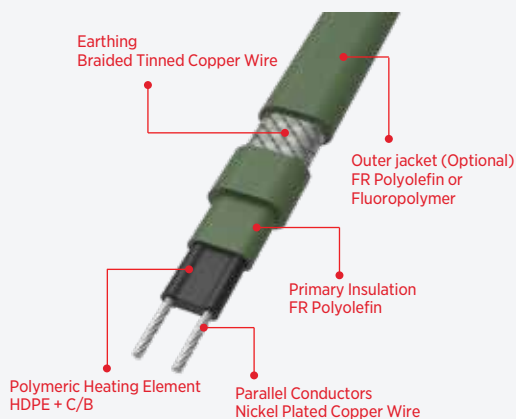

Frost protection of various mains cold (MCWS) and chilled water services (CHWS) pipework which are either located outdoors where there is the risk of sub-zero ambient temperatures or indoors within buildings where heating could be switched off. For these applications we would recommend Solco self-regulating heating cable type; HSR102-CP, HSR162-CP or HSR242-CP dependent upon pipe size, pipe material and thermal insulation type and thickness.

#### Solco HSR cable

The HSR product range is a conductive polymer self-regulating heating cable with a power output of 10W/m, 16W/m and 24W/m at +10°C when powered at 230 Vac 50Hz . This heating cable can withstand continuous exposure to +65°C (Power ON) and +85°C (Power OFF), making it the ideal selection for cold and chilled water services. Typically MCWS operate at +10°C to +20°C whereas CHWS operate at +4°C to +7°C but need to be maintained at a minimum of +5°C during worst case ambient temperature conditions.

In general, the HSR heating cable will be installed as a single straight trace using glass cloth fixing tape at 300mm spacing. On plastic pipes, we would recommend that adhesive backed aluminium foil tape is installed over the top of the heating cable along the full length of the pipe run to maximise the efficiency of the trace heating system.

Control of this frost protection system is achieved with Solco ambient / line sensing electronic controller type: Smart-ECO. This controller has a maximum switching capacity of 20A and provides a fault relay alarm output to the BMS as well as High Level (HL) and Low Level (LL) temperature alarm facilities.

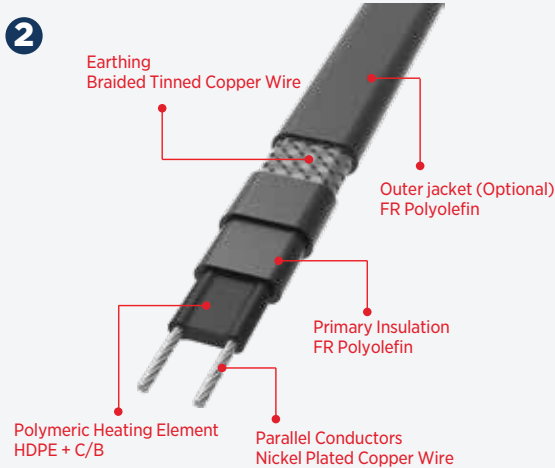

### Solco MSR cable

Frost protection of low temperature hot water (LTHW) services, which would typically operate in the temperature range of +82°C (flow) and +71°C (return). This duty is required when the hot water system is not operational and there is a requirement to frost protect the LTHW pipework where there is the risk of exposure to sub-zero ambient temperatures.

For this application we would recommend Solco self-regulating heating cable type MSR202-CP dependent upon pipe size, pipe material and thermal insulation type and thickness.

The MSR product range is a conductive polymer self-regulating heating cable with a power output of 20W/m at +10°C when powered at 230Vac 50Hz.

This heating cable can withstand continuous exposure to +80°C (Power ON) and +100°C (Power OFF) which is appropriate for this application.

In general, the MSR heating will be installed as a single straight trace using glass cloth fixing tape at 300mm spacing.

Control of this frost protection system is achieved with Solco ambient / line sensing electronic controller type: Smart-ECO. This controller has a maximum switching capacity of 20A and provides a fault relay alarm output to the BMS as well as High Level (HL) and Low Level (LL) temperature alarm facilities.

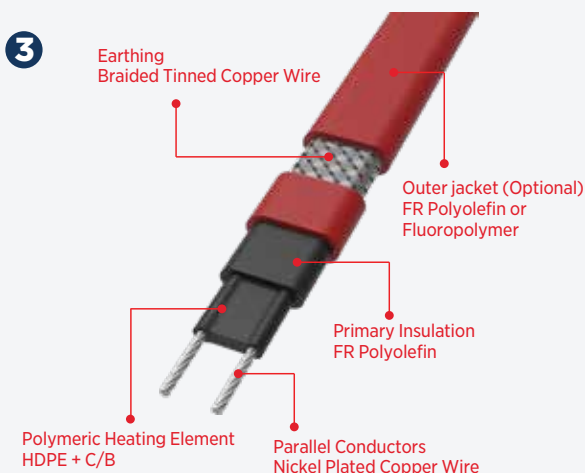

### Solco HWS cable

Temperature maintenance of hot water services (HWS) feed pipework to either eliminate the need for recirculation pipework or to trace heat the 'droppers' or 'dead legs' where the hot water service runs from the hot water main down to within 1 metre of the individual points of use (eg taps, thermostats etc).

Typically the application is to maintain pipe temperatures in the range of +50°C to +70°C with or without periodic disinfection to protect against the risk of legionella bacteria.

For this application we would recommend Solco self-regulating heating cable type: HWS-R or HWS-P (dependent on whether periodic boost required for disinfection) and selection will also be dependent upon pipe size and thermal insulation type and thickness.

The HWS-R has a power output of 9W/m at +55°C and the HWS-P has a power output of 9.5W/m at +70°C when powered at 230Vac 50Hz.

The HWS range of heating cables can withstand continuous exposure to +80°C (Power ON) and +100°C (Power OFF) which is ideal for hot water services pipework.

Control of hot water temperature maintenance systems is achieved using either the Solco line sensing electronic controller type: Smart-ECO or type: Smart-PRO sophisticated electronic controller with PT-100 sensor, soft start, 24hrs / 365day fault monitoring and TTL-RS232 comms port (convertible to most commonly used communication protocols) for BMS interface.

## General information

Solco is a high quality manufacturer of conductive polymer self-regulating heating cables, components, controls and accessories; these heating cables will not overheat or burn out and therefore are inherently safe.

All of our self-regulating heating cables, components, controls and accessories are fully compliant with BS EN 62395-1:2013 and we run accredited installer programmes to ensure that installation, testing and commissioning of Solco electrical trace heating systems fully comply with BS EN 62395-2:2013.

In order to ensure that our high quality manufactured heating cables become high quality installed trace heating systems providing high reliability in service, we have set up an accredited installer programme which involves four training modules that need to be successfully completed. We then provide a company accreditation certificate as well as accredited installer passports which are each valid for 3 years.

We hope that the above information is helpful guidance on the technical specifications for electrical trace heating systems for pipework typically encountered within the Building Services / Commercial market sector. If you need any further information or assistance, please do not hesitate to contact us.

# FROST PROTECTION OF WATER PIPEWORK

## Using Electrical Trace Heating

During winter months, pipework systems located outdoors or within unheated buildings are vulnerable to water freezing inside the pipework causing an expansion in volume as the water turns to ice - often resulting in the bursting of these pipes.

Burst water pipes costs the insurance industry £600M+ in claims during periods of prolonged sub-zero ambient temperatures.

When pipes burst, they often cause substantial consequential damages due to water leaking as well as the direct cost of replacing pipework and the business interruption caused by the loss of water supply.

There is a common misunderstanding that water pipes can be adequately protected from freezing by the application of a layer of thermal insulation around the pipework; this is incorrect! The reality is that thermal insulation has the effect of delaying the water pipe from freezing, it does NOT eliminate the risk, it simply delays the problem by a few hours.

The only solution that guarantees water pipes won't freeze under prolonged low ambient temperatures below 0 °C is to install electrical trace heating cable on the pipework which is then fitted with a layer of thermal insulation.

The tables below provide you with Solco heating cable selection guidance for a wide range of pipe materials based upon a minimum ambient temperature of minus 15 °C and a recommended thickness of a mineral fiber / Rockwool thermal insulation by pipe size.

### ① Copper pipework (metric)

Pipe OD (mm)	Insulation Thickness (mm)	Maximum Heat Loss (W/m)	Heating Cable Type	Trace Ratio
8	20	2.53	HSR102-CP	1.0
10	20	2.81	HSR102-CP	1.0
15	20	3.48	HSR102-CP	1.0
22	20	4.39	HSR102-CP	1.0
28	20	5.10	HSR102-CP	1.0
35	20	5.94	HSR102-CP	1.0
42	20	6.76	HSR102-CP	1.0
67	20	9.66	HSR102-CP	1.0
76	20	10.70	HSR102-CP	1.0
108	35	9.06	HSR102-CP	1.0
133	35	10.70	HSR102-CP	1.0
159	50	9.27	HSR102-CP	1.0

## 2 Carbon steel & stainless steel pipework (imperial/metric)

Pipe NB (inch) Pipe OD (mm)	Insulation Thickness (mm)	Maximum Heat Loss (W/m)	Heating Cable Type	Trace Ratio
3/8"/17.1	20	3.75	HSR102-CP	1.0
1/2"/21.3	20	4.28	HSR102-CP	1.0
1"/33.4	20	5.75	HSR102-CP	1.0
1 1/2"/48.3	20	7.50	HSR102-CP	1.0
2"/60.3	20	8.89	HSR102-CP	1.0
3"/88.9	30	8.77	HSR102-CP	1.0
4"/114.3	30	10.72	HSR102-CP	1.0
6"/168.3	40	11.63	HSR162-CP	1.0
8"/219.1	50	12.03	HSR162-CP	1.0
10"/273.0	50	14.50	HSR162-CP	1.0
12"/323.9	50	16.82	HSR162-CP	1.0

## 3 PVC-U plastic pipework (metric) - to BS EN1452

Pipe NB (inch) Pipe OD (mm)	Insulation Thickness (mm)	Maximum Heat Loss (W/m)	Heating Cable Type	Trace Ratio
3/8"/16	20	3.61	HSR102-CP	1.0
1/2"/20	20	4.12	HSR102-CP	1.0
3/4"/25	20	4.74	HSR102-CP	1.0
1"/32	20	5.58	HSR102-CP	1.0
1 1/4"/40	20	6.53	HSR102-CP	1.0
1 1/2"/50	20	7.70	HSR102-CP	1.0
2"/63	20	9.20	HSR162-CP	1.0
2 1/2"/75	20	10.58	HSR162-CP	1.0
3"/90	30	8.86	HSR162-CP	1.0
4"/110	30	10.39	HSR162-CP	1.0
5"/125	40	9.15	HSR162-CP	1.0
5"/140	40	10.01	HSR162-CP	1.0
6"/160	50	9.32	HSR162-CP	1.0
6"/180	50	10.24	HSR162-CP	1.0
8"/200	50	11.16	HSR162-CP	1.0
8"/225	50	12.30	HSR162-CP	1.0
10"/250	50	13.45	HSR242-CP	1.0
12"/315	50	16.41	HSR242-CP	1.0

- Maximum circuit length of HSR102-CP = 193 metres when protected with a 20A Type 'C' MCB.
- Maximum circuit length of HSR162-CP = 162 metres when protected with a 20A Type 'C' MCB.
- Maximum circuit length of HSR242-CP = 101 metres when protected with a 20A Type 'C' MCB.
- For energy efficiency frost protection systems should be controlled using our Smart-ECO digital controller in ambient sensing mode, which has a maximum switching capacity of 20A.

▲ **NOTE:** Please ensure that you use our SP-AFT-45 adhesive-backed aluminium foil over the top of the heating cable on ALL plastic pipe applications to achieve most efficient heat transfer. 110Vac products are available on request - HSR101-CP, HSR161-CP and HSR241-CP.

## HOT WATER TEMPERATURE MAINTENANCE USING ELECTRICAL TRACE HEATING

Modern Hot Water Services (HWS) are increasingly being designed to eliminate recirculation pipework in favour of the installation of a single HWS flow pipe which is electrically trace heated with the required thickness of thermal insulation to balance heat losses.

The result is a less complex pipework installation at lower cost with lower heat losses, lower energy consumption and the elimination of water going to waste until hot water reaches the point of use. Electrical trace heating delivers instant hot water at the point of use with the capacity to provide disinfection of the pipework to protect against Legionella bacteria.

### Elimination of HWS Recirculation Loop and the need for a “Balancing Function”

The greatest savings can be achieved by the complete elimination of the recirculating pipework loop from the hot water system which is especially relevant to the longer, more complex pipework runs within commercial buildings, hospitals, hotels, colleges, schools, universities etc.

This simpler hot water flow pipework system achieves a number of important savings:-

- 1) Reduced pipework installation costs
- 2) Reduced space requirements in building risers, shafts and utility racks etc
- 3) Reduced energy consumption as heat losses are balanced by the trace heating on flow only
- 4) Reduced water wastage as virtually instant hot water is delivered to the outlet on demand
- 5) Elimination of balancing function which is needed for a standard HWS Flow & Return system

### The need to Control Hot Water Temperatures on “Dead-Legs” and “Droppers”

In traditional hot water services with flow and return recirculation pipework, there is a need to ensure that the hot water in so called “dead legs” or “droppers” to outlets such as taps or thermostatic mixer valves (TMV’s) does not fall below at least +50°C. This ensures that you are not creating environmental conditions which could potentially promote the growth of Legionella Bacteria as highlighted in HSE document ref: HSG 274 Part 2 (2014) - “Control of Legionella Bacteria in Hot and Cold Water Systems”.

Again, electrical trace heating provides a simple and effective solution by the installation of a suitable conductive polymer self-regulating heating cable to each dropper and dead-leg so that these pipes are maintained at the target temperature (typically +50°C or +55°C in healthcare settings).

Depending upon the type of facility in which the hot water service is installed, some of these “droppers” and “dead-legs” can remain static for several hours which allows that hot water to lose temperature quite quickly to the ambient environment. Thermally insulating these sections of pipe only slows down the rate of heat loss and temperature drop and therefore the only way to ensure instant hot water when required is to install electrical trace heating with thermal insulation.

## Hot Water Services – Heater Selection Charts

There are typically two primary applications for electrical trace heating cable selection for hot water services temperature maintenance; these are assuming a minimum ambient temperature of +5°C and +18°C. Solco include the below selection charts for both situations and a maintain temperature of +55°C

Thermal insulation assumed to be Mineral Fibre / Rockwool (k factor – 0.038W/m.K)

Please consult us for advice on hot water temperature maintenance applications outside of this maintain temperature or minimum ambient temperature conditions.

### A) +55°C Hot Water Temperature Maintenance and +18°C Minimum Ambient

Pipe sizes based upon the most popular metric copper pipework typically used for building services / commercial hot water services systems.

Pipe OD (mm) (Copper)	Min. Insulation Thickness (mm)	Max Heat Loss (W/m)	Heating cable Type	Trace Ratio
10	15	7.65	HWS-R	1.0
15	20	8.16	HWS-R	1.0
22	25	9.00	HWS-R	1.0
28	30	9.26	HWS-R	1.0
35	40	8.91	HWS-R	1.0
42	50	8.70	HWS-R	1.0
54	30	14.19	HWS-P	1.0
67	35	14.82	HWS-P	1.0
76	40	14.74	HWS-P	1.0
108	55	5.10	HWS-P	1.0
133	70	14.74	HWS-P	1.0
159	80	15.23	HWS-P	1.0

- Maximum circuit length of HWS-R = 137 metres when protected with a 20A Type “C” MCB
- Maximum circuit length of HWS-P = 107 metres when protected with a 20A Type “C” MCB
- **We also recommend the use of RCD with a trip sensitivity of 30mA in max 100ms**
- Nominal Power Output of HWS-R at +55°C = 9.0 W/m (230Vac 50Hz)
- Nominal Power Output of HWS-P at +55°C = 16.3 W/m (230Vac 50Hz)
- **Trace Ratio is the metres of heating cable per metre of pipework**

## **B) +55°C Hot Water Temperature Maintenance and +5°C Minimum Ambient**

Pipe OD (mm) (Copper)	Min. Insulation Thickness (mm)	Max Heat Loss (W/m)	Heating cable Type	Trace Ratio
10	20	8.90	HWS-R	1.0
15	20	8.90	HWS-R	1.0
22	45	8.85	HWS-R	1.0
28	55	8.98	HWS-R	1.0
35	30	14.35	HWS-P	1.0
42	35	14.61	HWS-P	1.0
54	45	14.61	HWS-P	1.0
67	55	14.75	HWS-P	1.0
76	60	15.12	HWS-P	1.0
108	90	14.61	HWS-P	1.0
133	100	15.61	HWS-P	1.0
159	100	29.36	HWS-P	2.0

- Maximum circuit length of HWS-R = 107 metres when protected with a 20A Type “C” MCB
- Maximum circuit length of HWS-P = 71 metres when protected with a 20A Type “C” MCB
- **Each circuit to be protected with RCD with a trip sensitivity of 30mA with a max of 100ms**
- Nominal Power Output of HWS-R at +55°C = 9.0W/m (230Vac 50Hz)
- Nominal Power Output of HWS-P at +55°C = 16.3 W/m (230Vac 50Hz)
- **Trace Ratio is the metres of heating cable per metre of pipework (typ. 1.0)**

### **Control of Hot Water Temperature Maintenance Trace Heating Circuits**

Whilst the design of electrical trace heating systems need to balance the maximum heat loss from pipework which takes place under minimum ambient conditions, we also need to ensure that the temperature of the hot water is controlled under higher ambient temperatures.

This is achieved using the Smart-ECO electronic digital controller which is equipped with an NTC thermistor type sensor probe, enables the connection of up to two heating cables, and has a volt free output relay 2.0 SP DT. The Smart-ECO can directly switch heating loads up to 20A (max power 4000W).

High and Low level temperature alarms can be programmed into the device as well as a BMS fault alarm via the 2.0 SP DT output relay function.

**Please consult Solco for any hot water temperature maintenance design advice.**

# Contents

## 01 Heating Cables

HSR  
HSR-ZH  
HSR-D  
IPSR  
MSR  
HWS  
VSR  
VSR-D  
IcSR(e)  
IcSR  
SmSR

## 02 Monitoring & Control

Smart-IND  
Smart-ECO  
Smart-PAN  
Smart-PRO  
SP-MT-30  
ET-16

## 03 Connection Accessories

SP-HPEK / SP-HPK  
SP-CPEK / SP-CPK, SP-CEK  
SP-PTK-S  
SP-ETK-S  
SP-PTK-M  
SP-ETK-M  
SP-JBL  
SP-3JB  
SP-2JB  
SP-IEK  
SP-BRP-001 / 002 / 003 / 004  
SP-GCT  
SP-AFT-45

# Contents

# Heating Cables

HSR

HSR-ZH

HSR-D

IPSR

MSR

HWS

VSR

VSR-D

IcSR(e)

IcSR

SmSR

# 01





# Heating Cables

BEST QUALITY AND PERFORMANCE



SOLCO

## HSR

Self-regulating heating cable, max 65°C (ON), 85°C (OFF). 10-30 W/m, 200-277 Vac (100-120 Vac optional). FR polyolefin or fluoropolymer jackets.

## HSR-D

Self-regulating heating cable, Low-voltage (12-24 Vdc), 12 & 17 W/m, max 65°C (ON), 85°C (OFF). Chemical-resistant jackets (FR polyolefin or fluoropolymer).

## HSR-ZH

Self-regulating heating cable, 10-40 W/m, 200-277 Vac (100-120 Vac optional), max 80°C (ON), 100°C (OFF). Compact design.

## MSR

Self-regulating heating cable, 16-40 W/m, 100-240 Vac, max 80°C (ON), 100°C (OFF). AWG 16 conductors, FR polyolefin or fluoropolymer jackets.

## VSR

Self-regulating heating cable, 16-50 W/m, 100-240 Vac, max 110°C (ON), 135°C (OFF). Flame-retardant or chemical-resistant jackets.

## IcSR(e)

Self-regulating heating cable, 110-240 Vac, 30 & 40 W/m, max 110°C (ON), 135°C (OFF). Compact size, corrosion-resistant or water-resistant jackets.

## IPSR

Self-regulating heating cable, 230 Vac, 13 W/m, max 50°C (ON), 85°C (OFF). Compact size, flame retardant outer jacket.

## HWS

Self-regulating heating cable, Hot water maintenance, 200-240 Vac, 9-9.5 W/m, max 80°C (ON), 100°C (OFF). Compact, efficient.

## VSR-D

Self-regulating heating cable, Low-voltage high-temp, 12-24 Vdc, 12 & 17 W/m, max 110°C (ON), 135°C (OFF). Flame-retardant or chemical-resistant jackets.

## IcSR

Self-regulating heating cable, 50 W/m @0°C, 200-240 Vac. Continuous use up to 80°C (ON), 100°C (OFF). Water-resistant polyolefin or corrosion-resistant fluoropolymer jackets.

## SmSR

Self-regulating heating cable, 230 Vac, 100 W/m for concrete, max 110°C (ON), 135°C (OFF). Robust conductors, durable EVA jacket.



## Product Drawing

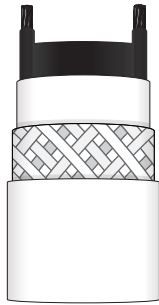

- Parallel Conductors
- Polymeric Heating Element
- Primary Insulation
- Earthing
- Outer Jacket
- Nickel Plated Copper Wire
- Polyolefin + C/B
- FR Polyolefin
- Braided Tinned Copper Wire Nickel
- PE + C/B FR Polyolefin (-P)
- PVDF(-F)

## Power Output Graph

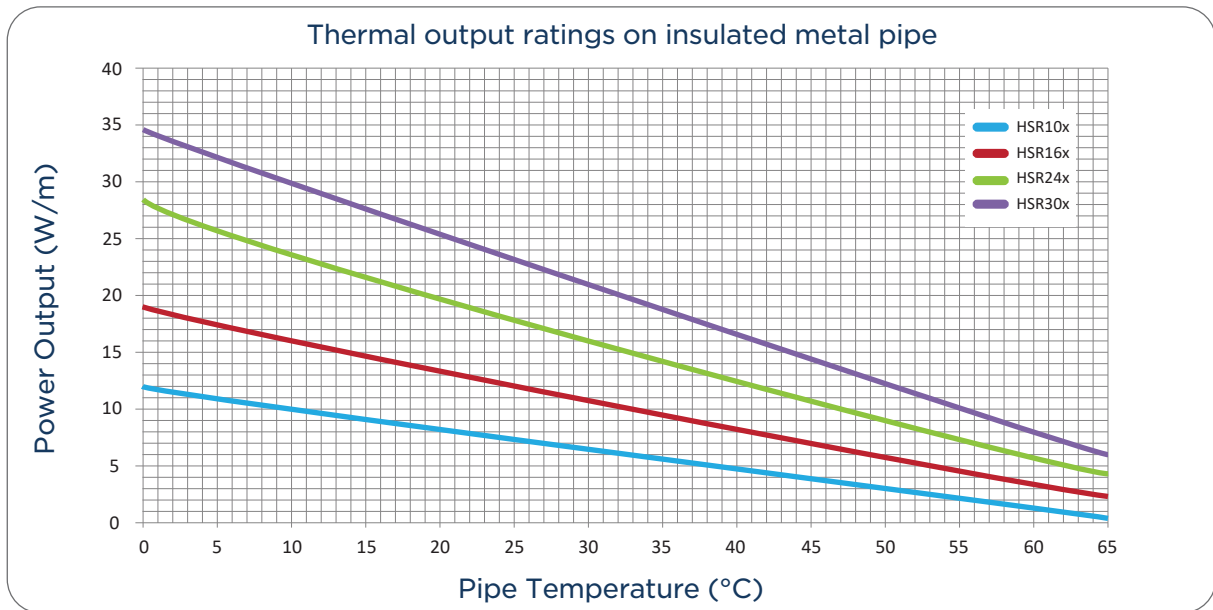

## Circuit Breaker Selection

Max. circuit length (m) at 230Vac based on starting temp. (°C) and typical Type C circuit breaker size (Amps).

Product code	Breaker Size(A)	Start-up Temp. -20°C						Start-up Temp. 0°C						Start-up Temp. 10°C					
		10A	16A	20A	25A	32A	40A	10A	16A	20A	25A	32A	40A	10A	16A	20A	25A	32A	40A
HSR102-CP(F)		84	134	155	155	155	155	101	162	169	169	169	169	131	193	193	193	193	193
HSR162-CP(F)		59	94	118	129	129	129	71	113	141	142	142	142	92	147	162	162	162	162
HSR242-CP(F)		42	67	84	104	111	111	36	57	71	89	114	117	50	81	101	126	126	126
HSR302-CP(F)		32	51	64	80	101	101	32	51	64	80	102	113	41	66	82	102	124	124

Max. circuit length (m) at 110Vac based on starting temp. (°C) and typical Type C circuit breaker size (Amps).

Product code	Breaker Size(A)	Start-up Temp. -20°C						Start-up Temp. 0°C						Start-up Temp. 10°C					
		10A	16A	20A	25A	32A	40A	10A	16A	20A	25A	32A	40A	10A	16A	20A	25A	32A	40A
HSR101 -CP(F)		42	63	71	N/A	N/A	N/A							76	87	87	87	87	N/A
HSR161 -CP(F)		19	29	39	N/A	N/A	N/A	N/A	N/A	N/A	N/A	N/A	N/A	39	58	71	71	71	N/A
HSR241-CP(F)		9	14	19	N/A	N/A	N/A							19	29	38	48	57	N/A
HSR301-CP(F)		8	12	16	N/A	N/A	N/A							15	22	30	37	45	N/A

# HSR-ZH LOW SMOKE ZERO HALOGEN

Self-regulating heating cable for modern commercial and residential buildings designed to meet LSZH regulations



<b>Use</b>	The insulation and sheath materials of the HSR-ZH cable provide a safe and reliable solution for modern building designs, meeting Low Smoke Zero Halogen (LSZH) requirements to enhance safety and reduce toxic emissions in case of fire.								
<b>Specifications</b>	<p><b>Max. continuous exposure temperature (power-ON)</b>  <b>HSR102, -162, -242, -302 model:</b> 65°C (150°F)  <b>HSR402 model:</b> 80°C (176°F)</p> <p><b>Max. intermittent exposure temperature (power-OFF)</b>  <b>HSR102, 162, 242, 302 model:</b> 85°C (185°F)  <b>HSR402 model:</b> 100°C (212°F)</p> <p><b>Rated voltage:</b> 200 ~ 277 Vac, (100 ~ 120 Vac available)  <b>Rated power output:</b> 10, 16, 24, 30 &amp; 40 Watts/m @10°C  <b>Dimension (nom.) :</b>  <b>HSR102, 162, 242 model:</b> 11.4mm x 5.4mm (±0.2mm)  <b>HSR302, 402 model:</b> 13.4 mm x 5.4mm(±0.2mm)  <b>Minimum bending Radius:</b> 25mm  <b>Parallel conductors:</b> ASTM B355 Class 2 NPC, AWG 16 (1.5mm<sup>2</sup>)  <b>Less smoke emissions:</b> IEC61034-2 tested and compliant  <b>Zero halogen:</b> IEC60754-1 tested and compliant  <b>Flame retardancy:</b> IEC62395- 1 tested and compliant</p>								
<b>Features</b>	<ul style="list-style-type: none"> <li>• Prevents overheating or burnout, even when overlapped</li> <li>• Self-regulating thermal performance that adjusts automatically to ambient temperature</li> <li>• Can be cut to any desired length for versatile installation in various conditions</li> <li>• Provides independent heat output control along the entire cable length</li> <li>• Ensures smooth power ON/OFF transitions, reducing stress on the heating core for greater energy efficiency and longer service life</li> <li>• Enables quick and easy termination for power connection, end sealing, and splicing</li> </ul>								
<b>Selection Code</b>	<p><u>HSR</u>   <u>30</u>   <u>2</u>   -   Z   <u>H</u>          (a)   (b)   (c)   (d)</p> <table border="1"> <tr> <td>(a)</td> <td>Model</td> </tr> <tr> <td>(b)</td> <td>Rated Output 10, 16, 24, 30, 40 Watts/m @10°C</td> </tr> <tr> <td>(c)</td> <td>Rated Voltage 1: 100 ~ 120 Vac , 2 : 200 ~ 277 Vac</td> </tr> <tr> <td>(d)</td> <td>The insulation and sheath material Low Smoke Zero Halogen</td> </tr> </table>	(a)	Model	(b)	Rated Output 10, 16, 24, 30, 40 Watts/m @10°C	(c)	Rated Voltage 1: 100 ~ 120 Vac , 2 : 200 ~ 277 Vac	(d)	The insulation and sheath material Low Smoke Zero Halogen
(a)	Model								
(b)	Rated Output 10, 16, 24, 30, 40 Watts/m @10°C								
(c)	Rated Voltage 1: 100 ~ 120 Vac , 2 : 200 ~ 277 Vac								
(d)	The insulation and sheath material Low Smoke Zero Halogen								
<b>Certification</b>									

## Product Drawing

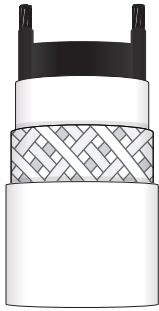

- Parallel Conductors
- Polymeric Heating Element
- Primary Insulation
- Earthing
- Outer Jacket
- Nickel Plated Copper Wire
- Polyolefin + C/B
- Low Smoke Zero halogen insulation
- Braided Tinned Copper Wire Nickel
- Low Smoke Zero Halogen outer jacket

## Power Output Graph

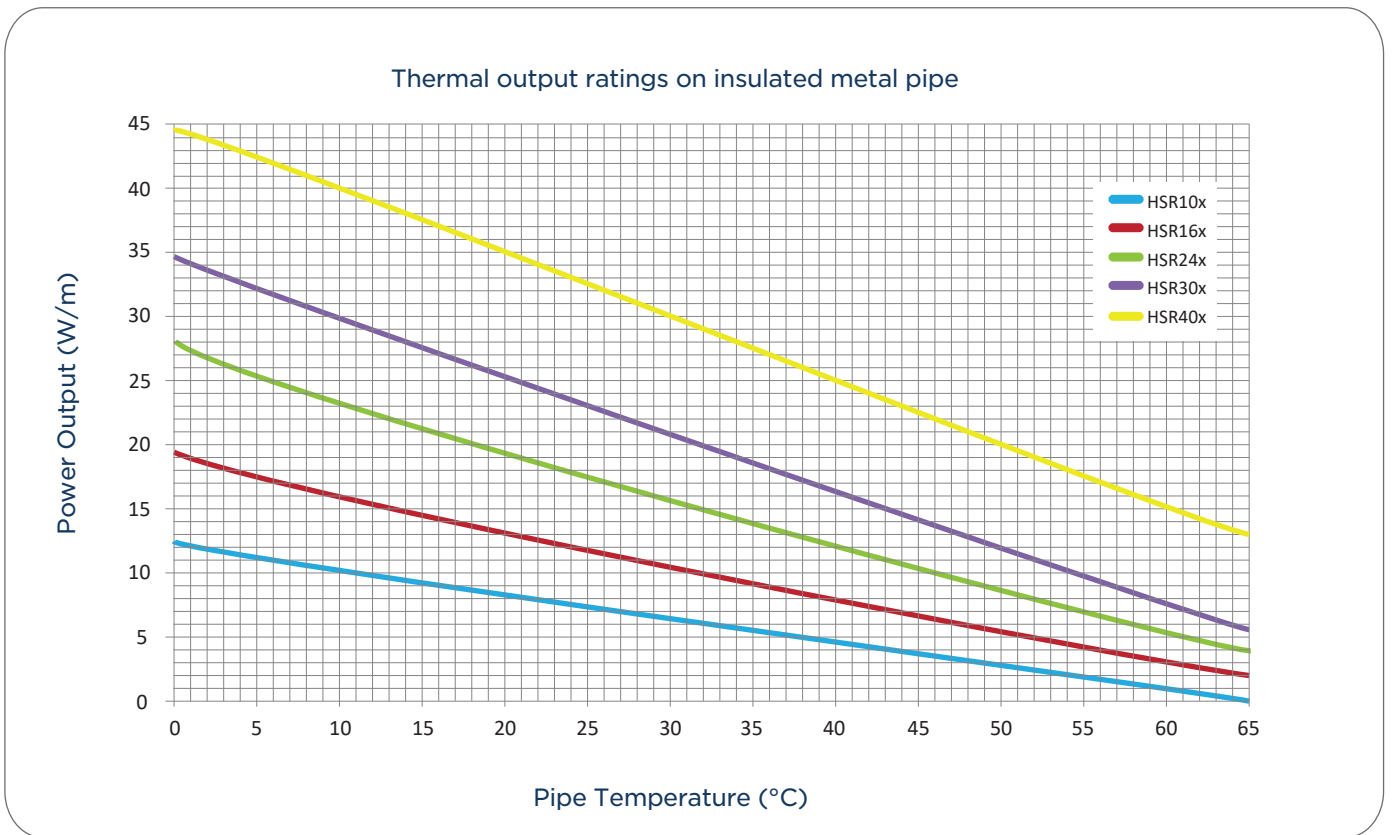

## Circuit Breaker Selection

Max. circuit length (m) at 230Vac based on starting temp. (°C) and typical Type C circuit breaker size (Amps).

Product code	Breaker Size(A)	Start-up Temp. -20°C						Start-up Temp. 0°C						Start-up Temp. 10°C					
		10A	16A	20A	25A	32A	40A	10A	16A	20A	25A	32A	40A	10A	16A	20A	25A	32A	40A
HSR102-ZH		84	134	155	155	155	155	101	162	169	169	169	169	131	193	193	193	193	193
HSR162-ZH		59	94	118	129	129	129	71	113	141	142	142	142	92	147	162	162	162	162
HSR242-ZH		42	67	84	104	111	111	36	57	71	89	114	117	50	81	101	126	126	126
HSR302-ZH		32	51	64	80	101	101	32	51	64	80	102	113	41	66	82	102	124	124
HSR402-ZH		20	32	40	50	64	80	23	38	47	59	75	94	30	48	61	76	97	101

# HSR-D

Self-regulating heating cable for commercial automotive and construction industries  
Freeze protection and temperature maintenance applications



<p><b>Use</b></p>	<p>Suitable for a range of uses, these cables provide freeze protection for water pipelines and are compatible with battery-supplied low-voltage applications. They are also designed for temperature maintenance of fuel feed lines in the automotive sector and for use in camping equipment, ensuring reliable performance in varying environmental conditions.</p>								
<p><b>Specifications</b></p>	<p><b>Max. maintain temperature (Power-ON):</b> 65°C (150°F)  <b>Max. withstand temperature (Power-OFF):</b> 85°C (185°F)  <b>Temperature Classification (T-rating):</b> T6 (85°C )  <b>Rated voltage:</b> 12 ~ 24 Vdc  <b>Rated power output:</b> 12 &amp; 17 Watts/m @10°C  <b>Dimension (nom.):</b>  <b>HSR12D &amp; HSR17D:</b> 11.4mm x 5.4mm  <b>Minimun bending Radius:</b> 25mm  <b>Parallel conductors:</b> ASTM B355 Class 2 NPC, AWG 16 (1.5mm<sup>2</sup>)</p> <p><b>Outer Jacket</b>  <b>FR polyolefin (CP):</b> Exposure to aqueous inorganic chemicals  <b>Fluoropolymer (CF):</b> Exposure to organic chemicals or corrosives</p>								
<p><b>Features</b></p>	<ul style="list-style-type: none"> <li>• Will not overheat or burn out, even when overlapped</li> <li>• Self-regulates thermal performance in response to ambient temperature</li> <li>• Can be cut to any required length to suit specific installation conditions</li> <li>• Provides independent heat output control along the entire cable length</li> <li>• Ensures smooth power ON/OFF transitions, minimizing stress on the heating core to enhance energy efficiency and extend service life</li> <li>• Allows for simple and reliable termination for power connection, end sealing, and splicing</li> </ul>								
<p><b>Selection Code</b></p>	<p>HSR <u>12</u> <u>D</u> <u>2</u> - C <u>P</u>                  (a) (b) (c) (d)</p> <table border="1"> <tr> <td>(a)</td> <td>Model</td> </tr> <tr> <td>(b)</td> <td>Rated Output 12 and 17 Watts/m @10°C</td> </tr> <tr> <td>(c)</td> <td>Rated Voltage 1 : 12 Vdc, 2 : 24 Vdc</td> </tr> <tr> <td>(d)</td> <td>Outer Jacket P : FR Polyolefin, F : Fluoropolymer</td> </tr> </table>	(a)	Model	(b)	Rated Output 12 and 17 Watts/m @10°C	(c)	Rated Voltage 1 : 12 Vdc, 2 : 24 Vdc	(d)	Outer Jacket P : FR Polyolefin, F : Fluoropolymer
(a)	Model								
(b)	Rated Output 12 and 17 Watts/m @10°C								
(c)	Rated Voltage 1 : 12 Vdc, 2 : 24 Vdc								
(d)	Outer Jacket P : FR Polyolefin, F : Fluoropolymer								
<p><b>Certification</b></p>	<p>CE UK CA</p>								

## Product Drawing



- Parallel Conductors: Nickel Plated Copper Wire
- Polymeric Heating Element: HDPE + C/B
- Primary Insulation: FR Polyolefin
- Earthing: Braided Tinned Copper Wire Nickel
- Outer Jacket: FR Polyolefin (-P)  
Fluoropolymer (-F)

## Power Output Graph

Thermal output ratings on insulated metal pipe

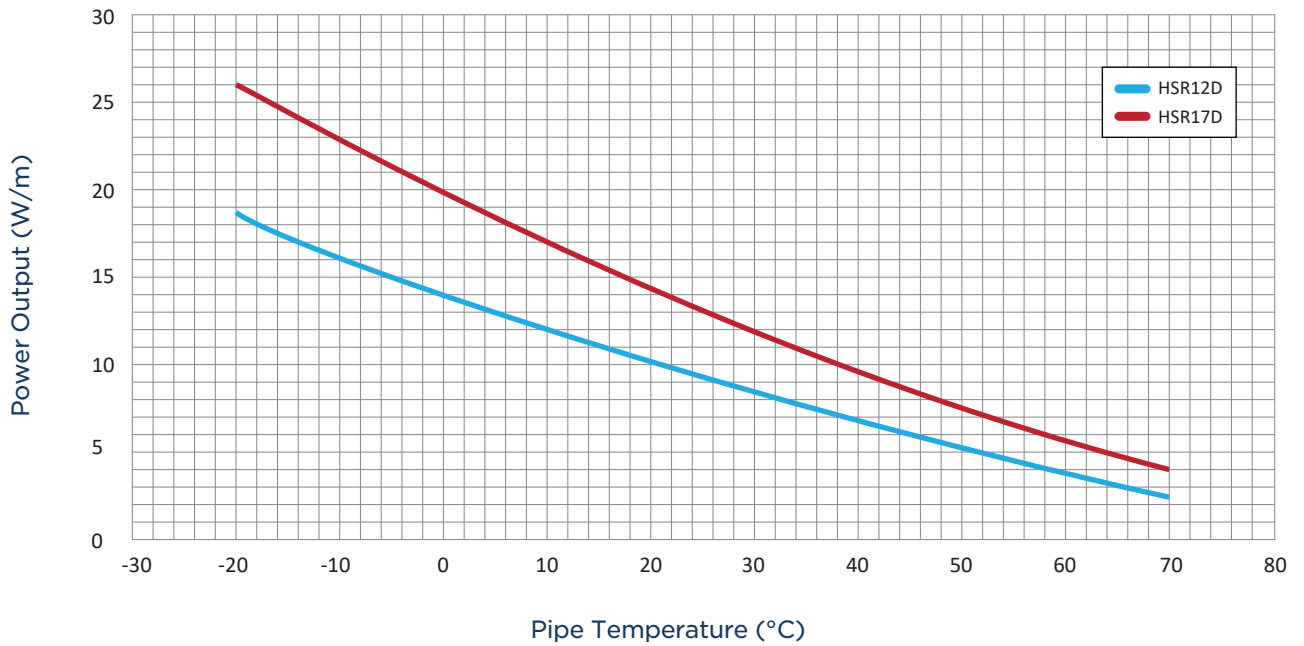

## Circuit Breaker Selection

Max. circuit length (m) at 24Vdc based on starting temp. (°C) and typical Type C circuit breaker size (Amps).

Product code	Breaker Size(A)	Start-up Temp. -20°C						Start-up Temp. 10°C						
		10A	16A	20A	25A	32A	40A	10A	16A	20A	25A	32A	40A	
HSR12D		8	13	16	16	16	16	13	19	19	19	19	19	19
HSR17D		6	10	13	14	14	14	10	15	17	17	17	17	17

# IPSR

Self-regulating heating cable for fire sprinkler freeze protection applications and for applications with restricted installation space



<p><b>Use</b></p>	<p>Designed for dependable performance, these cables provide effective freeze protection for water pipework in holiday parks, including cabins, caravans, and camping vehicles. They are also suitable for safeguarding fire sprinkler pipework systems and small-bore pipes, ensuring reliable operation and preventing damage under cold conditions.</p>								
<p><b>Specifications</b></p>	<p><b>Max. maintain temperature (Power-ON):</b> 50°C (122°F)  <b>Max. withstand temperature (Power-OFF):</b> 85°C (185°F)  <b>Rated voltage:</b> 230 Vac  <b>Rated power output:</b> 13 Watts/m @10°C  <b>Dimension (nom.) :</b> 8.3mm x 6.0 mm  <b>Minimun bending Radius:</b> 25mm  <b>Parallel Conductors:</b> ASTM B355 Class 2 NPC, AWG 19, 0.65mm<sup>2</sup>  <b>Outer Jacket:</b> FR Polyolefin</p>								
<p><b>Features</b></p>	<ul style="list-style-type: none"> <li>• Will not overheat or burn out, even when overlapped</li> <li>• Self-regulates thermal performance according to ambient temperature</li> <li>• Can be cut to any desired length for flexible installation in various conditions</li> <li>• Provides independent heat output control along the entire cable length</li> <li>• Features smooth power ON/OFF transitions, minimizing stress on the heating cable core to improve energy efficiency and extend service life</li> <li>• Enables easy and secure termination for power connection, end sealing, and splicing</li> </ul>								
<p><b>Selection Code</b></p>	<p>IPSR    13    C    P                (a)    (b)    (c)    (d)</p> <table border="1"> <tr> <td>(a)</td> <td>Model</td> </tr> <tr> <td>(b)</td> <td>Rated Output 13 Watts/m @10°C</td> </tr> <tr> <td>(c)</td> <td>Tin plated copper wire braid</td> </tr> <tr> <td>(d)</td> <td>Outer Jacket P : Polyolefin</td> </tr> </table>	(a)	Model	(b)	Rated Output 13 Watts/m @10°C	(c)	Tin plated copper wire braid	(d)	Outer Jacket P : Polyolefin
(a)	Model								
(b)	Rated Output 13 Watts/m @10°C								
(c)	Tin plated copper wire braid								
(d)	Outer Jacket P : Polyolefin								
<p><b>Certification</b></p>	<p>CE UK CA</p>								

## Product Drawing



- Parallel Conductors      Nickel Plated Copper Wire
- Polymeric Heating Element      PE + C/B
- Primary Insulation      Polyolefin
- Earthing      Braided Tinned Copper Wire Nickel
- Outer Jacket      FR Polyolefin

## Power Output Graph

Thermal output ratings on insulated metal pipe

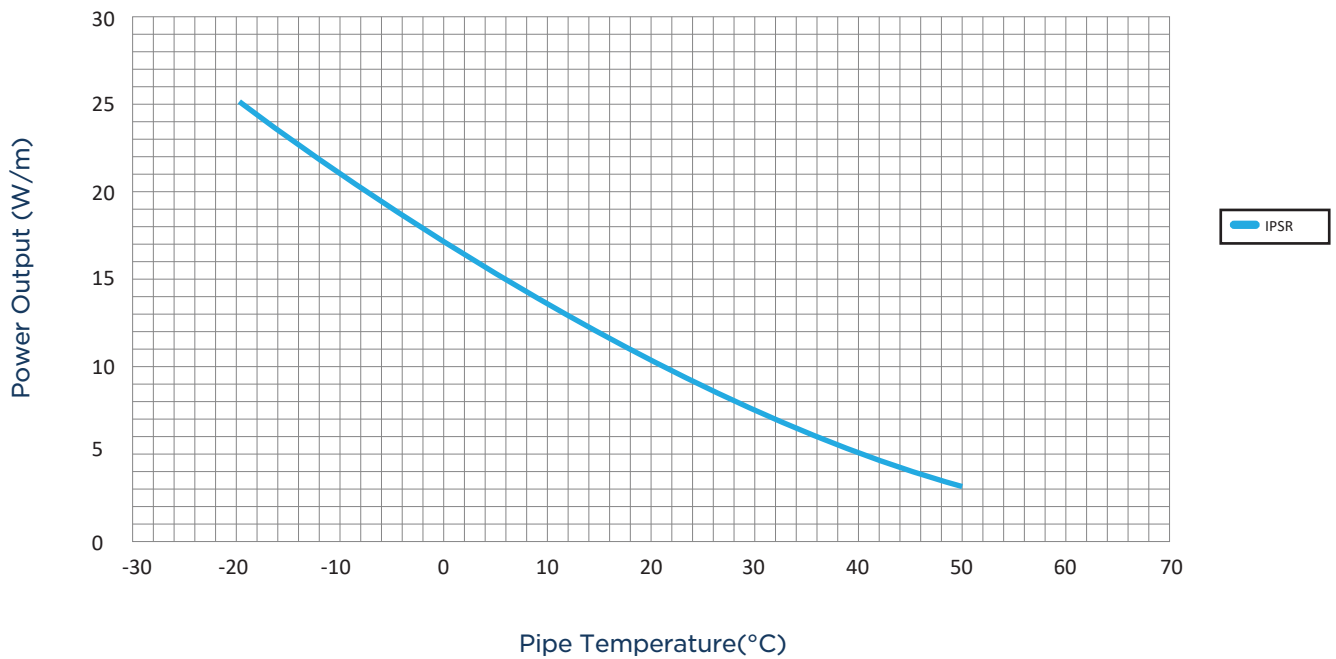

## Circuit Breaker Selection

Max. circuit length (m) at 230Vac based on starting temp. (°C) and typical Type C circuit breaker size (Amps).

Product code	Breaker Size(A)	Start-up Temp. -20°C						Start-up Temp. 0°C						Start-up Temp. 10°C					
		10A	16A	20A	25A	32A	40A	10A	16A	20A	25A	32A	40A	10A	16A	20A	25A	32A	40A
IPSR		66	105	124	124	124	124	97	150	150	150	150	150	101	162	169	169	169	169



## Product Drawing



- Parallel Conductors      Nickel Plated Copper Wire
- Polymeric Heating Element      HDPE + C/B
- Primary Insulation      Polyolefin
- Earthing      Braided Tinned Copper Wire Nickel
- Outer Jacket      FR Polyolefin (-P)  
Fluoropolymer(-F)

## Power Output Graph

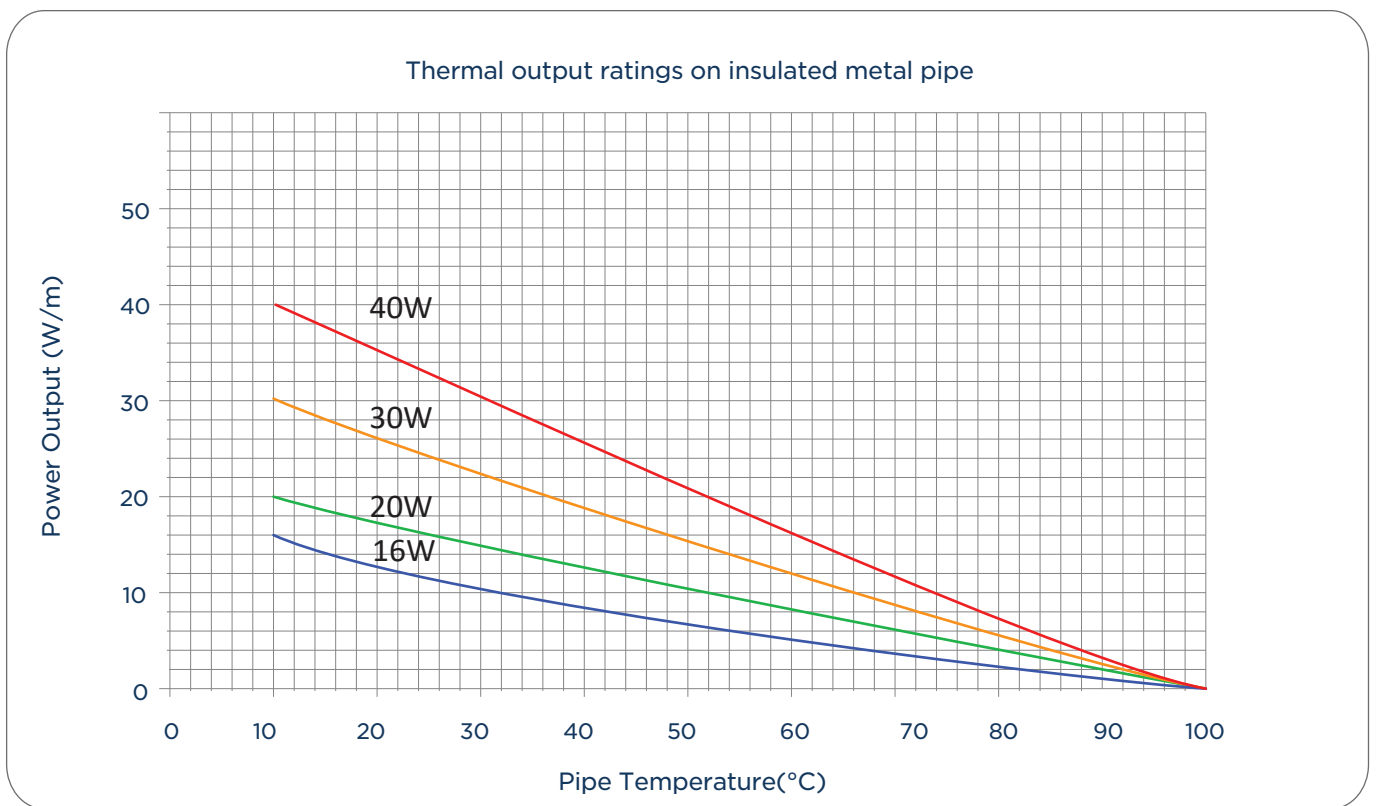

## Circuit Breaker Selection

Max. circuit length (m) at 230Vac based on starting temp. (°C) and typical Type C circuit breaker size (Amps).

Product code	Breaker Size(A)	Start-up Temp. -20°C						Start-up Temp. 0°C						Start-up Temp. 10°C					
		10A	16A	20A	25A	32A	40A	10A	16A	20A	25A	32A	40A	10A	16A	20A	25A	32A	40A
MSR162-CP(F)		46	64	83	106	119	119	50	71	107	114	129	129	55	82	126	131	141	141
MSR202-CP(F)		36	58	73	91	108	108	38	61	77	96	120	120	43	68	85	106	126	126
MSR302-CP(F)		27	43	54	67	86	99	32	51	63	79	101	110	41	65	82	102	115	115
MSR402-CP(F)		20	32	40	50	64	80	23	38	47	59	75	94	30	48	61	76	97	101



## Product Drawing

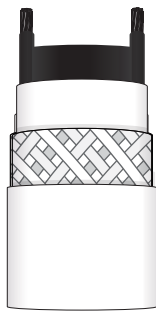

- Parallel Conductors      Nickel Plated Copper Wire
- Polymeric Heating Element      HDPE + C/B
- Primary Insulation      FR Polyolefin
- Earthing      Braided Tinned Copper Wire Nickel
- Outer Jacket      FR Polyolefin or Fluoropolymer

## Power Output Graph

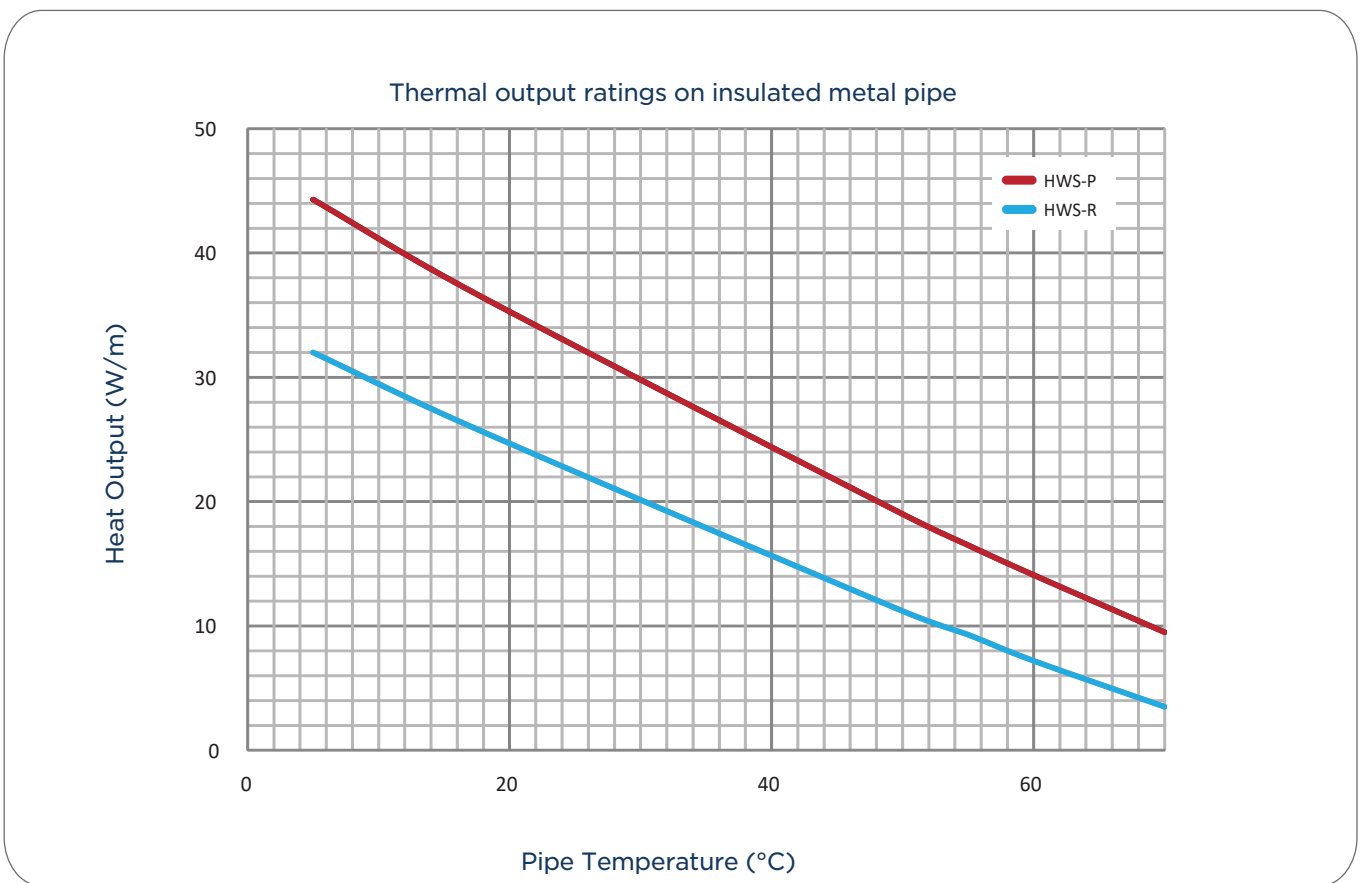

## Circuit Breaker Selection

Max. circuit length (m) at 230Vac based on starting temp. (°C) and typical Type C circuit breaker size (Amps).

Product code \ Breaker Size(A)	Start-up Temp. 5°C					Start-up Temp. 18°C				
	6A	10A	16A	20A	32A	6A	10A	16A	20A	32A
HWS-R	32	53	85	107	122	45	74	119	137	137
HWS-P	21	36	57	71	112	32	53	85	107	126

# VSR

Self-regulating heating cable for industrial process flow control  
Freeze protection and temperature maintenance applications



<p><b>Use</b></p>	<p>These cables are engineered for versatile heating applications, including freeze protection of water pipelines, temperature maintenance in petrochemical and gas plants, snow melting for outdoor facilities, and floor warming in commercial buildings. They are also suitable for OEM heated panels and certified for use in hazardous locations (Ex e IIC Gb, IECEx), ensuring safety and compliance in demanding environments.</p>												
<p><b>Specifications</b></p>	<p> <b>Max. maintain temperature (Power-ON):</b> 110°C (230°F)  <b>Max. withstand temperature (Power-OFF):</b> 135°C (275°F)  <b>Temperature Classification (T-rating):</b> T4 (135°C)  <b>Rated voltage:</b> 100 ~ 240 Vac  <b>Rated power output:</b> 16, 24, 30, 40 &amp; 50 Watts/m @10°C  <b>Dimension (nom.) :</b>  <b>VSR162 ~ VSR402:</b> 13.1mm x 5.6mm  <b>VSR502:</b> 14.5mm x 5.6mm  <b>Minimum bending Radius:</b> 30mm  <b>Parallel Conductors:</b> ASTM B355 Class 2 NPC, AWG 16, 1.5mm<sup>2</sup>  <b>Outer Jacket</b>  <b>XLEVA (CX):</b> Flame retardant  <b>Fluoropolymer (CT):</b> Exposure to organic chemicals or corrosives                 </p>												
<p><b>Features</b></p>	<ul style="list-style-type: none"> <li>• Will not overheat or burn out, even when overlapped</li> <li>• Self-regulates thermal performance in response to ambient temperature</li> <li>• Can be cut to any required length to suit a wide range of installation conditions</li> <li>• Provides independent heat output control along the entire length, smooth power ON/OFF transitions, minimizing stress on the heating core to enhance energy efficiency and extend service life</li> <li>• Enables quick and reliable termination for power connection, end sealing, and splicing</li> </ul>												
<p><b>Selection Code</b></p>	<p><u>VSR</u> a</p>	<p><u>30</u> b</p>	<p><u>2</u> c</p>	<p>- C</p>	<p><u>X</u> d</p> <table border="1" data-bbox="478 1769 1332 1937"> <tr> <td>a</td> <td>Model</td> </tr> <tr> <td>b</td> <td>Rated Output 16, 24, 30, 40, 50 Watts/m @10°C</td> </tr> <tr> <td>c</td> <td>Rated Voltage 1 : 100 ~ 120Vac, 2 : 200 ~ 240 Vac</td> </tr> <tr> <td>d</td> <td>Outer Jacket X : XLEVA, T : FEP</td> </tr> </table>	a	Model	b	Rated Output 16, 24, 30, 40, 50 Watts/m @10°C	c	Rated Voltage 1 : 100 ~ 120Vac, 2 : 200 ~ 240 Vac	d	Outer Jacket X : XLEVA, T : FEP
a	Model												
b	Rated Output 16, 24, 30, 40, 50 Watts/m @10°C												
c	Rated Voltage 1 : 100 ~ 120Vac, 2 : 200 ~ 240 Vac												
d	Outer Jacket X : XLEVA, T : FEP												
<p><b>Certification</b></p>	<p>CE UK CA</p>												

## Product Drawing

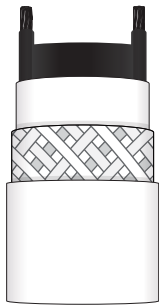

- Parallel Conductors: Nickel Plated Copper Wire
- Polymeric Heating Element: Fluoropolymer + C/B
- Primary Insulation: FR Polyolefin
- Earthing: Braided Tinned Copper Wire Nickel
- Outer Jacket: PE + C/B FR Polyolefin (-P)  
PVDF(-F)

## Power Output Graph

Thermal output ratings on insulated metal pipe

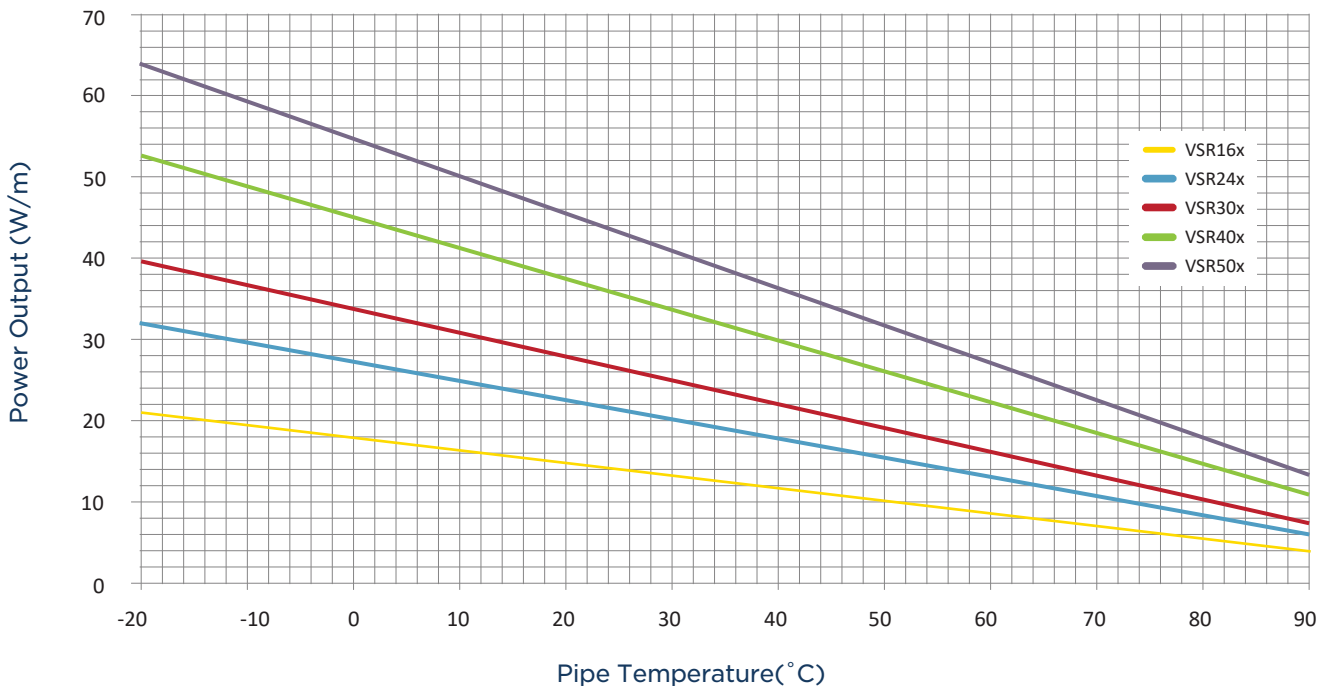

## Circuit Breaker Selection

Max. circuit length (m) at 230Vac based on starting temp. (°C) and typical Type C circuit breaker size (Amps).

Breaker Size(A) Product code	Start-up Temp. -50 °C						Start-up Temp. -20 °C						Start-up Temp. 0 °C						Start-up Temp. 10 °C					
	10A	16A	20A	25A	32A	40A	10A	16A	20A	25A	32A	40A	10A	16A	20A	25A	32A	40A	10A	16A	20A	25A	32A	40A
VSR162	49	78	97	118	118	118	58	92	116	128	128	128	70	112	140	141	141	141	77	123	148	148	148	148
VSR242	36	58	73	91	102	102	43	69	87	108	111	111	52	84	105	122	122	122	58	92	115	128	128	128
VSR302	31	50	62	78	94	94	37	59	73	91	102	102	44	70	88	110	112	112	49	78	97	117	117	117
VSR402	26	42	52	65	83	86	31	49	61	76	93	93	36	58	73	91	102	102	40	64	80	100	107	107
VSR502	23	36	45	56	72	80	26	41	51	64	81	85	30	48	60	75	93	93	33	53	66	82	97	97

# VSR-D

Self-regulating heating cable for commercial, automotive and construction industries  
 Freeze protection and temperature maintenance applications



<p><b>Use</b></p>	<p>These cables are designed for a variety of heating applications, including freeze protection of water pipelines, battery-supplied low-voltage applications, and OEM heated panels. They also provide reliable temperature maintenance for fuel feed lines in the automotive sector, ensuring safe and efficient operation across different environments.</p>								
<p><b>Specifications</b></p>	<p> <b>Max. maintain temperature (Power-ON):</b> 110°C (230°F)  <b>Max. withstand temperature (Power-OFF):</b> 135°C (275°F)  <b>Temperature Classification (T-rating):</b> T4 (135°C)  <b>Rated voltage:</b> 12 ~ 24 Vdc  <b>Rated power output:</b> 12 &amp; 17 Watts/m @10°C  <b>Dimension (nom.) :</b>  <b>VSR12 &amp; VSR17:</b> 13.5mm x 5.8mm  <b>Minimun bending Radius:</b> 30mm  <b>Parallel Conductors:</b> ASTM B355 Class 2 NPC, AWG 16, 1.5mm<sup>2</sup>  <b>Outer Jacket</b>  <b>XLEVA (CX):</b> Flame retardant  <b>Fluoropolymer (CT):</b> Exposure to organic chemicals or corrosives                 </p>								
<p><b>Features</b></p>	<ul style="list-style-type: none"> <li>• Will not overheat or burn out, even when overlapped</li> <li>• Self-regulates thermal performance in response to ambient temperature</li> <li>• Can be cut to any required length to accommodate diverse installation conditions</li> <li>• Provides independent heat output control along the entire cable length</li> <li>• Ensures smooth power ON/OFF transitions, minimizing stress on the heating cable core to enhance energy efficiency and extend service life</li> </ul>								
<p><b>Selection Code</b></p>	<p> <u>VSR</u>   <u>12</u>   <u>D</u>   <u>2</u>   -   C   <u>X</u>                  (a)   (b)   (c)   (d)             </p> <table border="1" data-bbox="496 1727 1342 1883"> <tr> <td>(a)</td> <td>Model</td> </tr> <tr> <td>(b)</td> <td>Rated Output 12 &amp; 17 Watts/m @10°C</td> </tr> <tr> <td>(c)</td> <td>Rated Voltage 1 : 12 Vdc, 2 : 24 Vdc</td> </tr> <tr> <td>(d)</td> <td>Outer Jacket X : XLEVA, T : FEP</td> </tr> </table>	(a)	Model	(b)	Rated Output 12 & 17 Watts/m @10°C	(c)	Rated Voltage 1 : 12 Vdc, 2 : 24 Vdc	(d)	Outer Jacket X : XLEVA, T : FEP
(a)	Model								
(b)	Rated Output 12 & 17 Watts/m @10°C								
(c)	Rated Voltage 1 : 12 Vdc, 2 : 24 Vdc								
(d)	Outer Jacket X : XLEVA, T : FEP								
<p><b>Certification</b></p>									

## Product Drawing

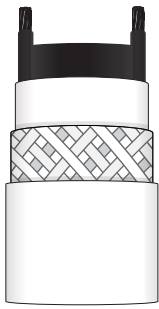

- Parallel Conductors: Nickel Plated Copper Wire
- Polymeric Heating Element: Fluoropolymer + C/B
- Primary Insulation: XLEVA
- Earthing: Braided Tinned Copper Wire Nickel
- Outer Jacket: XLEVA (CX) Fluoropolymer (CT)

## Power Output Graph

Thermal output ratings on insulated metal pipe

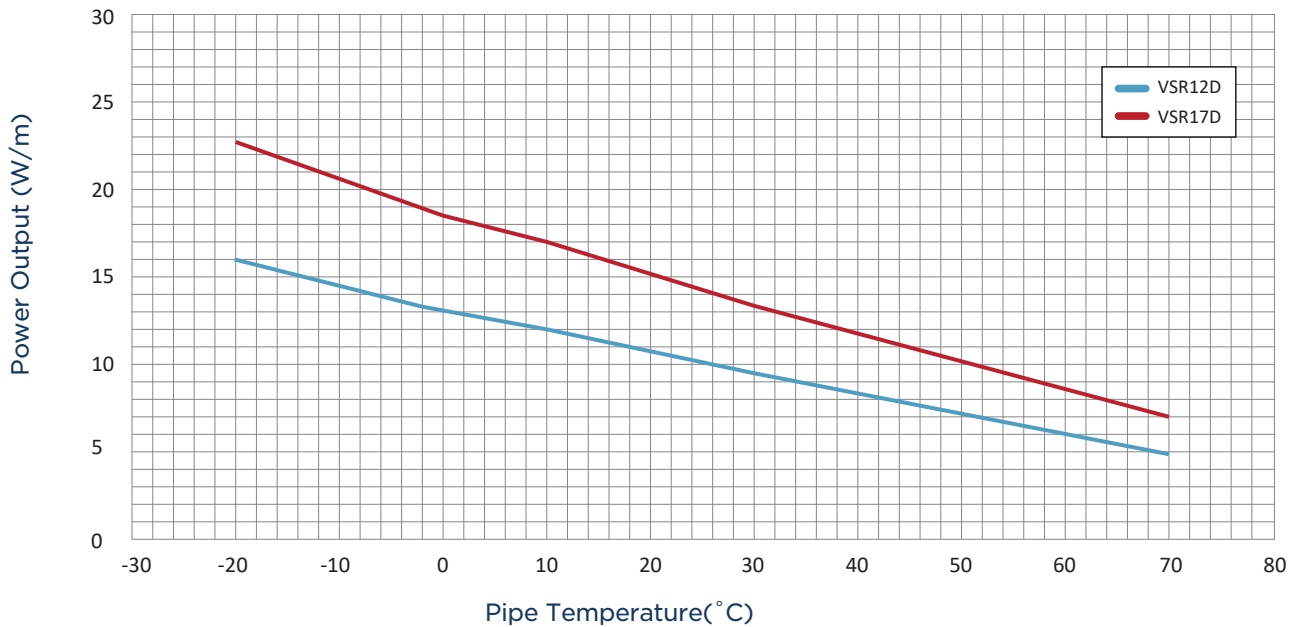

## Circuit Breaker Selection

Max. circuit length (m) at 24Vdc based on starting temp. (°C) and typical Type C circuit breaker size (Amps).

Product code \ Breaker Size(A)	Start-up Temp. -20°C						Start-up Temp. 10°C					
	10A	16A	20A	25A	32A	40A	10A	16A	20A	25A	32A	40A
VSR12D	10	15	17	17	17	17	13	19	19	19	19	19
VSR17D	7	12	14	15	15	15	10	15	17	17	17	17

# IcSR(e)

Self-regulating heating cable for snow melting and icicle prevention applications



<p><b>Use</b></p>	<p>These cables are designed for effective snow and ice management, including snow melting at leisure resorts, building construction industry and airports etc. They also prevent icicle formation on outdoor buildings and provide anti-icing protection for roofs, gutters, and drain pipes, ensuring safety and reducing maintenance in cold conditions.</p>										
<p><b>Specifications</b></p>	<p><b>Max. maintain temperature (Power-ON):</b> 80°C (176°F)  <b>Max. withstand temperature (Power-OFF):</b> 100°C (212°F)  <b>Rated voltage:</b> 200 ~ 240 Vac  <b>Rated power output:</b> 30, 40 Watts/m @0°C (Ice water)  <b>Dimension (nom.) :</b> 13.4mm ~ 5.4mm  <b>Minimun bending Radius:</b> 25mm  <b>Parallel conductors:</b> ASTM B355 Class 2 NPC, AWG 16, 1.5mm2</p> <p><b>Outer Jacket</b>  <b>Polyolefin (CP):</b> Water resistant  <b>Fluoropolymer (CF):</b> Corrosive area</p>										
<p><b>Features</b></p>	<ul style="list-style-type: none"> <li>• Will not overheat or burn out, even when overlapped</li> <li>• Self-regulates thermal performance in response to ambient temperature</li> <li>• Can be cut to any required length to accommodate various installation conditions</li> <li>• Provides independent heat output control along the entire cable length</li> <li>• Ensures smooth power ON/OFF transitions, minimizing stress on the heating cable core to enhance energy efficiency and extend service life</li> <li>• Allows easy and secure termination for power connection, end sealing, and splicing</li> <li>• Flexible and flat design adapts to complex or irregular surfaces</li> <li>• Weatherproof construction – resistant to UV exposure, heat, and rain</li> </ul>										
<p><b>Selection Code</b></p>	<p>IcSR (e) 40 2 - C P                  (a) (b) (c) (d) (e)</p> <table border="1"> <tr> <td>(a)</td> <td>Model</td> </tr> <tr> <td>(b)</td> <td>Economy</td> </tr> <tr> <td>(c)</td> <td>Rated Output Watts/m @0°C</td> </tr> <tr> <td>(d)</td> <td>Rated Voltage 200 ~ 240 Vac</td> </tr> <tr> <td>(e)</td> <td>Outer Jacket P : UV resist, Polyolefin, F : Fluoropolymer</td> </tr> </table>	(a)	Model	(b)	Economy	(c)	Rated Output Watts/m @0°C	(d)	Rated Voltage 200 ~ 240 Vac	(e)	Outer Jacket P : UV resist, Polyolefin, F : Fluoropolymer
(a)	Model										
(b)	Economy										
(c)	Rated Output Watts/m @0°C										
(d)	Rated Voltage 200 ~ 240 Vac										
(e)	Outer Jacket P : UV resist, Polyolefin, F : Fluoropolymer										
<p><b>Certification</b></p>	<p>CE UK CA</p>										

## Product Drawing



- Parallel Conductors      Nickel Coated Copper Wire
- Polymeric Heating Element      Fluoropolymer + C/B
- Primary Insulation      Polyolefin
- Earthing      Braided Tinned Copper Wire Nickel
- Outer Jacket      Polyolefin (-P)  
Fluoropolymer(-F)

## Power Output Graph

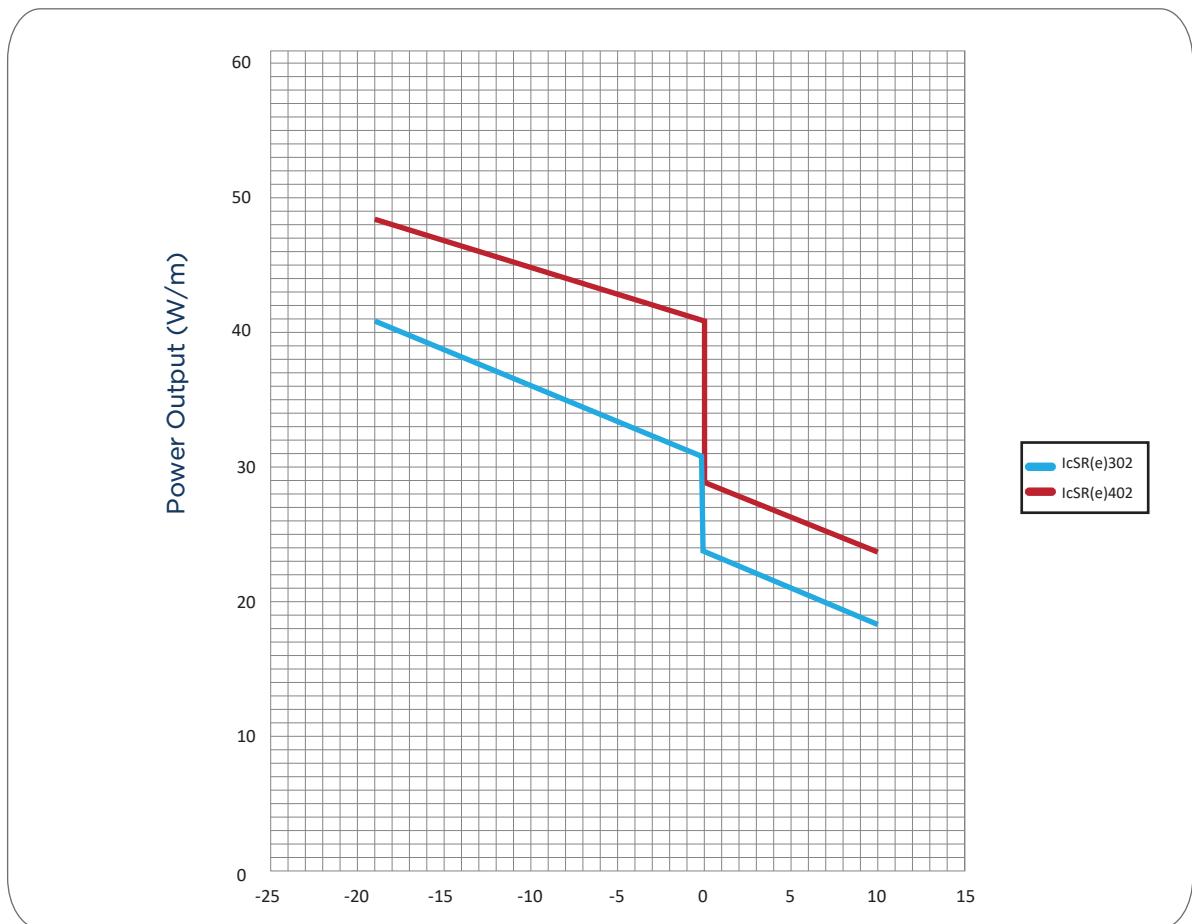

## Circuit Breaker Selection

Max. circuit length (m) at 230Vac based on starting temp. (°C) and typical Type C circuit breaker size (Amps).

Product code	Breaker Size(A)	Start-up Temp. -20°C						Start-up Temp. 0°C					
		10A	16A	20A	25A	32A	40A	10A	16A	20A	25A	32A	40A
IcSR(e)302-CP(F)		30	48	60	75	78	78	40	64	80	91	91	91
IcSR(e)402-CP(F)		23	37	46	58	70	70	28	45	57	70	76	76

# IcSR

Self-regulating heating cable for snow melting and icicle prevention applications



<p><b>Use</b></p>	<p>Designed for outdoor ice and snow management, these cables support snow melting at leisure resorts, highways, roads, and airports. They also prevent icicle formation on buildings and provide anti-icing protection for roofs, gutters, and drain pipes, enhancing safety and reducing maintenance in cold conditions.</p>								
<p><b>Specifications</b></p>	<p><b>Max. maintain temperature (Power-ON):</b> 80°C (176°F)  <b>Max. withstand temperature (Power-OFF):</b> 100°C (212°F)  <b>Rated voltage:</b> 200 ~ 240 Vac  <b>Rated power output:</b> 50 Watts/m @0°C (Ice water)  <b>Dimension (nom.) :</b> 13.5mm ~ 5.6mm  <b>Minimun bending Radius:</b> 25mm  <b>Parallel conductors:</b> ASTM B355 Class 2 NPC, AWG 16,1.5mm<sup>2</sup>  <b>Outer Jacket</b>  <b>Polyolefin (CP):</b> Water resistance  <b>Fluoropolymer (CF):</b> Corrosive area</p>								
<p><b>Features</b></p>	<ul style="list-style-type: none"> <li>• Will not overheat or burn out, even when overlapped</li> <li>• Self-regulates thermal performance according to ambient temperature</li> <li>• Can be cut to any required length to suit diverse installation conditions</li> <li>• Provides independent heat output control along the entire cable length</li> <li>• Ensures smooth power ON/OFF transitions, minimizing stress on the heating cable core to enhance energy efficiency and extend service life</li> <li>• Allows easy and reliable termination for power connection, end sealing, and splicing</li> <li>• Flexible and flat design adapts to complex or irregular surfaces</li> <li>• Weatherproof construction, resistant to UV, heat, and rain</li> </ul>								
<p><b>Selection Code</b></p>	<p>IcSR   <u>50</u>   <u>2</u>   -   C   <u>P</u>                  (a)   (b)   (c)   (d)</p> <table border="1"> <tr> <td>(a)</td> <td>Model</td> </tr> <tr> <td>(b)</td> <td>Rated Output Watts/m @0°C</td> </tr> <tr> <td>(c)</td> <td>Rated Voltage 200 ~ 240 Vac</td> </tr> <tr> <td>(d)</td> <td>Outer Jacket P : UV resist, Polyolefin, F : Fluoropolymer</td> </tr> </table>	(a)	Model	(b)	Rated Output Watts/m @0°C	(c)	Rated Voltage 200 ~ 240 Vac	(d)	Outer Jacket P : UV resist, Polyolefin, F : Fluoropolymer
(a)	Model								
(b)	Rated Output Watts/m @0°C								
(c)	Rated Voltage 200 ~ 240 Vac								
(d)	Outer Jacket P : UV resist, Polyolefin, F : Fluoropolymer								
<p><b>Certification</b></p>	<p>CE UK CA</p>								

## Product Drawing

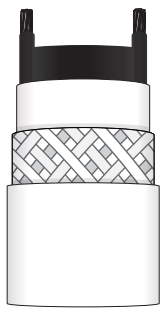

Parallel Conductors

Polymeric Heating Element

Primary Insulation

Earthing

Outer Jacket

Nickel Coated Copper Wire

Fluoropolymer + C/B

Water resistance Polyolefin

Braided Tinned Copper Wire Nickel

Polyolefin (-P) Fluoropolymer(-F)

## Power Output Graph

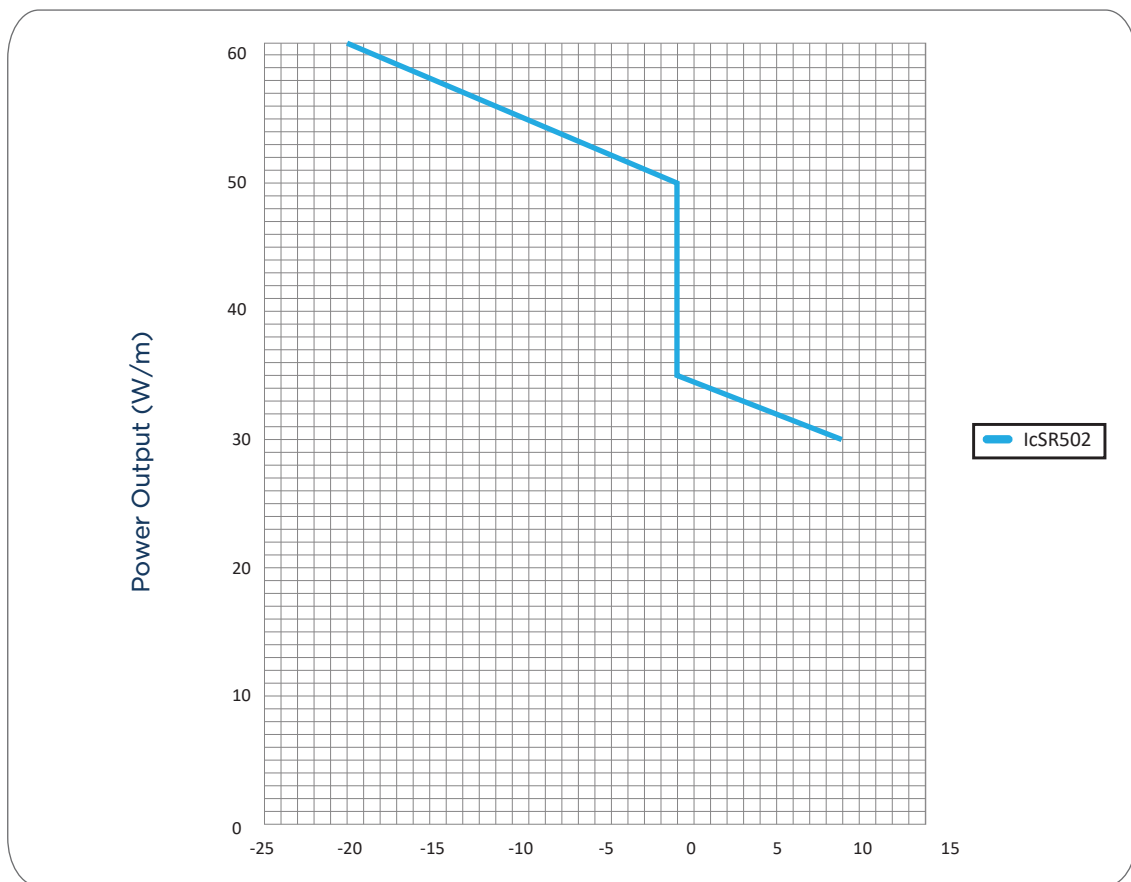

## Circuit Breaker Selection

Max. circuit length (m) at 230Vac based on starting temp. (°C) and typical Type C circuit breaker size (Amps).

Product code	Breaker Size(A)	Start-up Temp. -20°C						Start-up Temp. 0°C					
		6A	10A	16A	20A	32A	40A	6A	10A	16A	20A	32A	40A
IcSR502-CP(F)		17	28	34	43	54	60	20	33	41	51	65	65

# SmSR

Self-regulating heating cable for pavement snow melting and anti-icing applications



<p><b>Use</b></p>	<p>These systems are designed for comprehensive snow and ice management, including snow melting for all types of pavements, driveways, and car park ramps. They also prevent icicle formation on outdoor buildings and provide anti-icing protection for roofs, gutters, and drain pipes, ensuring safety and reducing maintenance in cold weather.</p>								
<p><b>Specifications:</b></p>	<p><b>Max. maintain temperature (Power-ON):</b> 80°C (176°F)  <b>Max. withstand temperature (Power-OFF):</b> 135°C (275°F)  <b>Rated voltage:</b> 230 Vac  <b>Rated power:</b> output @220Vac, 100Watts/m @0°C (in concrete)  <b>Dimension (nom.) :</b> 18.6mm ~ 9.4mm  <b>Minimum bending Radius:</b> 45mm  <b>Parallel Conductors:</b> ASTM B355 Class 2 NPC, AWG 14, 2.5mm<sup>2</sup>  <b>Outer Jacket:</b> Cross-Linked EVA</p>								
<p><b>Features</b></p>	<ul style="list-style-type: none"> <li>• Ideal solution for all types of pavement snow-melting and anti-icing applications</li> <li>• Will not overheat or burn out, even when overlapped</li> <li>• Self-regulates thermal performance according to ambient temperature</li> <li>• Can be cut to any required length to suit various installation conditions</li> <li>• Provides independent heat output control along the entire cable length</li> <li>• Ensures smooth power ON/OFF transitions, minimizing stress on the heating cable core to improve energy efficiency and extend service life</li> <li>• Requires no cold leads for cable entry</li> <li>• Robust construction with high temperature resistance</li> <li>• Weatherproof design, resistant to UV, heat, and rain</li> </ul>								
<p><b>Selection Code</b></p>	<p>SmSR 100 2 - C P                  (a) (b) (c) (d)</p> <table border="1"> <tr> <td>(a)</td> <td>Model</td> </tr> <tr> <td>(b)</td> <td>Power Watts/m@ 0°C (concrete)</td> </tr> <tr> <td>(c)</td> <td>Rated Voltage 230 Vac</td> </tr> <tr> <td>(d)</td> <td>Outer Jacket X : XLEVA</td> </tr> </table>	(a)	Model	(b)	Power Watts/m@ 0°C (concrete)	(c)	Rated Voltage 230 Vac	(d)	Outer Jacket X : XLEVA
(a)	Model								
(b)	Power Watts/m@ 0°C (concrete)								
(c)	Rated Voltage 230 Vac								
(d)	Outer Jacket X : XLEVA								
<p><b>Certification</b></p>	<p>CE UK CA</p>								

## Product Drawing



- Parallel Conductors      Nickel Plated Copper Wire
- Polymeric Heating Element      Fluoropolymer + C/B
- Primary Insulation      XLEVA
- Earthing      Braided Tinned Copper Wire Nickel
- Outer Jacket      XLEVA

## Thermal Output Graph

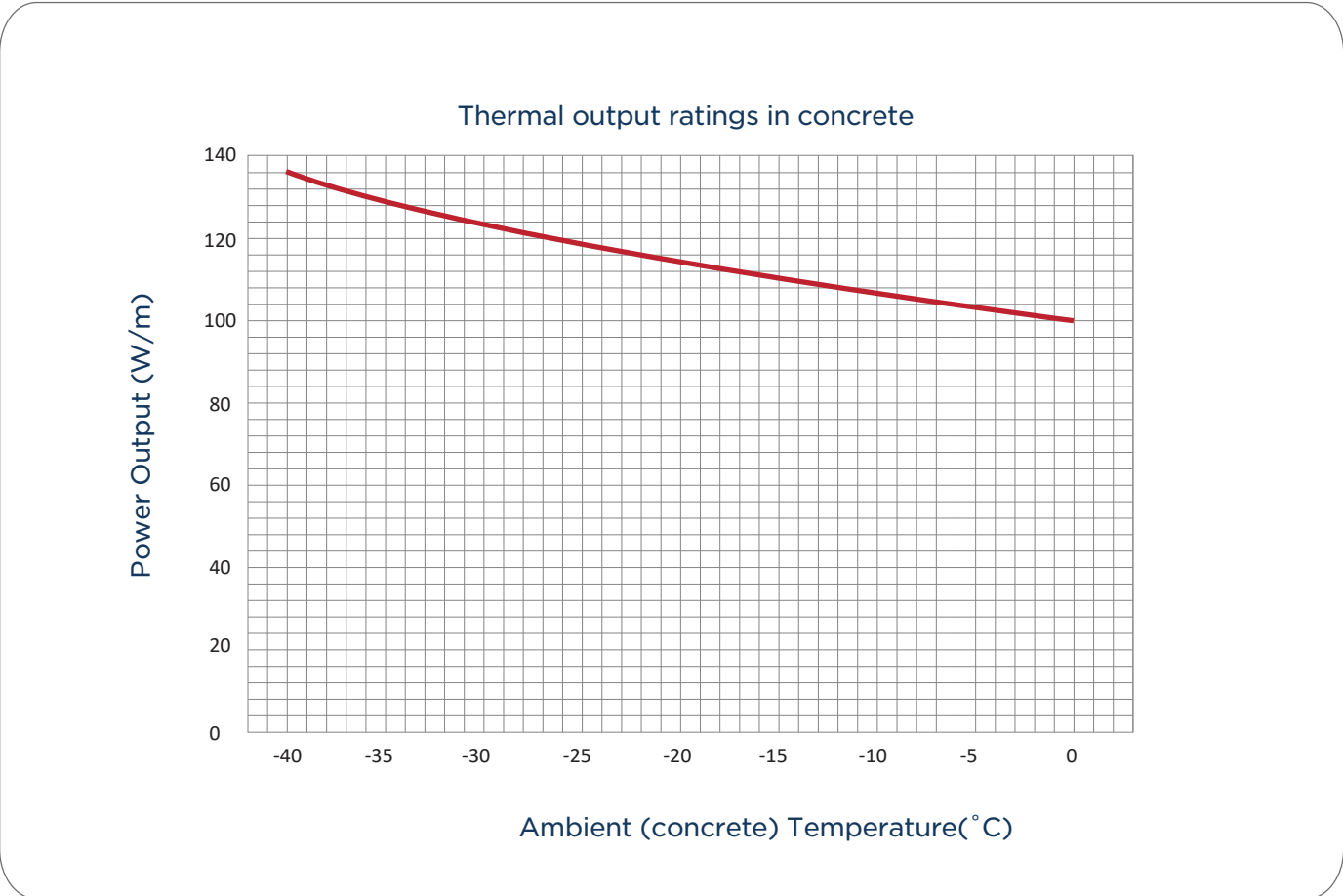

## Circuit Breaker Selection

Max. circuit length (m) at 230Vac based on starting temp. (°C) and typical Type C circuit breaker size (Amps).

Product code \ Breaker Size(A)	Start-up Temp. -18°C					Start-up Temp. 0°C (in concrete)				
	25A	30A	40A	50A	75A	25A	30A	40A	50A	75A
SmSR	37	44	59	73	73	46	56	74	81	81

# Monitoring and Control

Smart-IND  
Smart-ECO  
Smart-PAN  
Smart-PRO  
SP-MT-30  
ET-16

# 02





# Monitoring and Control

# Smart-IND

Air / surface sensing electronic thermostat with BMS fault alarm relay.  
For electronic temperature control in commercial heating applications.



<p><b>Description</b></p>	<p>This air/surface sensing programmable temperature control device features fault monitoring via TTL-RS232 communication and a BMS fault alarm relay. It is designed for precise electronic temperature control of trace heating systems across industrial, marine, and commercial applications, particularly in harsh environmental conditions.</p>	
<p><b>Features</b></p>	<ul style="list-style-type: none"> <li>• User-friendly design with easily programmable settings</li> <li>• Compatible with all Solco heating cables</li> <li>• Equipped with a 32A hybrid control relay for long life and a 3A SPST BMS fault alarm relay</li> <li>• Can be mounted on a Solco stainless steel pipe bracket for convenient installation</li> <li>• Intuitive user interface featuring:             <ul style="list-style-type: none"> <li>- 3 LED indicators for POWER, FAULT, and LOAD</li> <li>- Main 7-segment LED screen displaying alternating live and set temperature readings every minute</li> </ul> </li> </ul>	
<p><b>Technical Specification</b></p>	<p><b>Model:</b> <b>Supply voltage:</b> <b>Load current (max.):</b> <b>Ambient operating temperature range:</b> <b>Temperature measurement range:</b> <b>Temperature setting range:</b> <b>Ingress Protection(IP) rating:</b> <b>Enclosure material, size:</b> <b>Mounting:</b> <b>PCB terminal assembly:</b> <b>Inputs:</b> <b>Outputs:</b></p>	<p>Smart-IND v.01 100 Vac (min.) - 270 Vac (max.) 50 / 60 Hz 32A -20°C to +60°C -50°C to +450°C -45°C to +495°C IP66 GRP full enclosure, size 160 x 160 x 90 mm Brackets provided for wall / pipe mounting 9 x 4.0mm<sup>2</sup> max. conductor size 6 x 2.5mm<sup>2</sup> max. conductor size, WAGO lever type 1 x mains supply 1 x factory wired PT100 temperature sensor 2 x heating circuit 1 x safety relay output, 240Vac max. 3.0A SPST</p>
<p><b>Certification</b></p>	<p>CE UK CA</p>	

## Installation Guide

The Smart-IND can be mounted on a wall or support bracket supplied by Solco  
Simply undo the 4 screws in the lid to reveal through holes for mounting to the wall or bracket

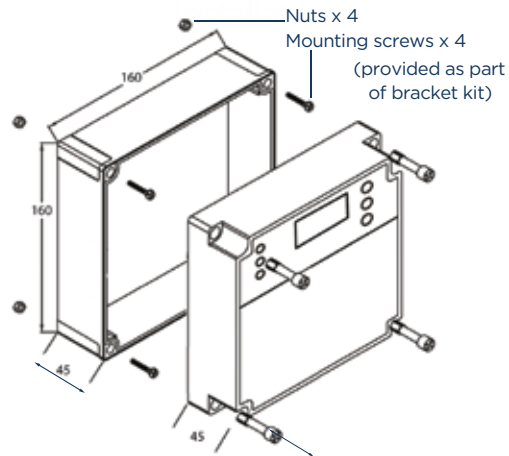

## Connection and controls

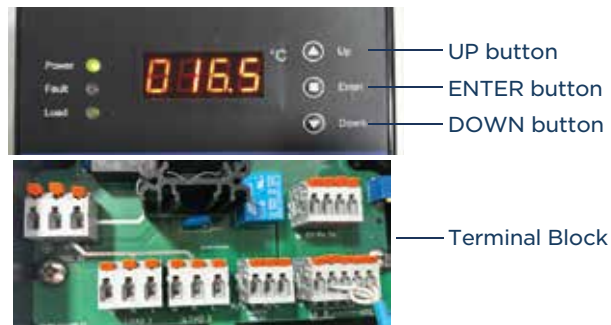

## Smart IND



# Smart-ECO

Air / surface sensing electronic thermostat with BMS fault alarm relay.  
For electronic temperature control in commercial heating applications.



Heating Solutions

<p><b>Description</b></p>	<p>This air/surface sensing programmable temperature control device, equipped with a BMS fault alarm relay, provides precise electronic temperature control of trace heating systems. It is particularly suited for freeze and frost protection in commercial, residential, and non-residential applications.</p>
<p><b>Features</b></p>	<ul style="list-style-type: none"> <li>• User-friendly design with easily programmable settings</li> <li>• Compatible with all SOLCO heating cables</li> <li>• Equipped with a 20A control relay and a 3A SPST BMS fault alarm relay</li> <li>• Can be mounted on a pipe using a SOLCO support bracket</li> <li>• Intuitive user interface featuring:             <ul style="list-style-type: none"> <li>- LED indicator for HEATING LOAD ON/OFF indication</li> <li>- Main 7-segment LED screen displaying alternating live and set temperature readings every minute</li> </ul> </li> </ul>
<p><b>Technical Specification</b></p>	<p><b>Model:</b> Smart-ECO</p> <p><b>Supply voltage:</b> 100 Vac (min.) – 270 Vac (max.), 50 / 60 Hz</p> <p><b>Load current (max.):</b> 20 A (Max. Power 4000 W)</p> <p><b>Ambient operating temperature range:</b> -20°C to +60°C</p> <p><b>Ingress protection:</b> IP66 / 67</p> <p><b>Enclosure material, size:</b> Body, ABS / lid, polycarbonate - size 125 x 175 x 75 mm</p> <p><b>Mounting:</b> Brackets provided for wall / pipe mounting</p> <p><b>Terminals (push-pull):</b> 14 x 2.5mm<sup>2</sup> max. conductor size (24 AWG – 14 AWG)</p> <p><b>Inputs:</b> 1 x mains supply, 1 x NTC type temperature sensor (factory wired)</p> <p><b>Outputs:</b> 2 x heating circuits, 1 x safety relay output, 240Vac max. 3.0 A SPST</p>
<p><b>Certification</b></p>	<p>CE UK CA</p>

## Installation Guide

The Smart-ECO air/surface sensing thermostat provides intuitive measurement and control for SOLCO heating cables. It features a 20A control relay and a 3A SPST BMS fault alarm relay, with parameters and alarm conditions displayed digitally for easy programming. Heater/load On and Off status is indicated by an amber LED. Supplied with an NTC thermistor sensor probe with a 3 m cable, the thermostat allows flexible placement of the electronics separate from the sensor. The unit is fully compatible with SOLCO heating cable termination kits for seamless installation.

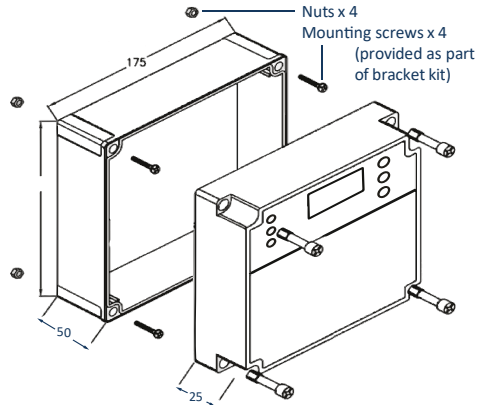

## Connection and controls



LED Display



- UP button
- ENTER button
- DOWN button



Terminal Block

## Smart ECO



# Smart-PAN

Air / surface Sensing Panel-Mounted Thermostat  
For electronic temperature control in commercial heating applications.



<p><b>Product Category</b></p>	<p>The Smart-PAN air/surface sensing panel-mounted thermostat is a user-friendly device designed for accurate measurement and control of SOLCO heating cables. It is suitable for all trace heating systems in industrial and commercial applications, providing reliable and precise temperature management.</p>
<p><b>Features</b></p>	<ul style="list-style-type: none"> <li>• Touch-screen interface for intuitive control and monitoring</li> <li>• MODULAR DESIGN - Supports up to 20 PT100 temperature sensors via upto 4 PCBs (5 sensors per PCB)</li> <li>• Real-time measurement display with alarm notifications for fault conditions</li> <li>• Fully programmable for:                         <ul style="list-style-type: none"> <li>- Temperature setpoints</li> <li>- Alarm limits</li> <li>- Safety relay operation</li> <li>- Fail-safe function</li> </ul> </li> <li>• Compatible with PT100 sensors (1m cable included; extendable up to 100m or shortened to 0.1m)</li> <li>• Designed for installation within IP-rated enclosures or trace heating control panels</li> <li>• Fail-safe relay configuration allows relay to be set ON or OFF during fault conditions, depending on application requirements</li> </ul>
<p><b>Technical Specification</b></p>	<p><b>Model:</b> Smart-PAN  <b>Application:</b> Air / surface sensing, -50°C to +500°C  <b>Area of use:</b> Non-hazardous, ordinary area  <b>Ambient operating temperature range:</b> -50°C to +60°C  <b>Temperature measurement range:</b> -50°C to +450°C  <b>Temperature setting range:</b> -45°C to +495°C  <b>Supply voltage :</b> 100Vac (min) – 270Vac (max), 50/60 Hz  <b>Load current (max.):</b> 32A (via contactor)  <b>Terminals (WAGO lever type):</b> 20 x 4.0mm<sup>2</sup> max.  <b>conductor size:</b> (24 – 12 AWG) per 5 sensor PCB</p>
<p><b>Certification</b></p>	

## Installation Guide

The integrated control software offers full programmability for temperature setpoints, alarm limits, safety relay operation, and fail-safe functions

### Important Notes:

1. Fail-safe Option:\*\* The heater/load relay can be configured to switch either ON or OFF in the event of a fault condition, depending on the application requirements.
2. Sensor Cable Length: The sensor cable supports a minimum length of 0.1m and a maximum length of 100m, using appropriately sized 3- or 4-core conductor wire.



## Connection and controls

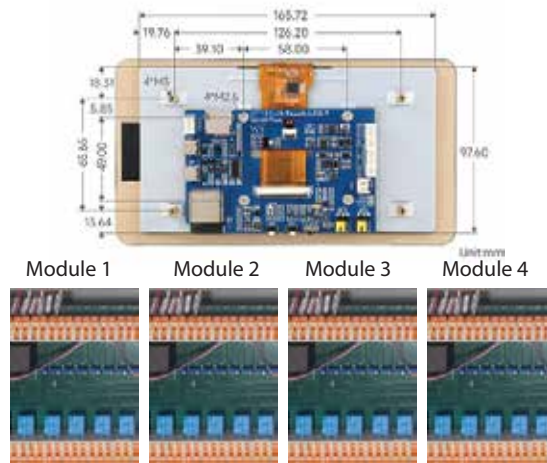

## Smart PAN



# Smart-PRO

Air / surface sensing electronic thermostat with BMS fault alarm relay.  
For electronic temperature control in commercial heating applications.



SOLCO  
Trace Heating Solutions

<p><b>Description</b></p>	<p>This air/surface sensing programmable temperature control device features innovative Soft-Start functionality, fault monitoring via TTL-RS232 communication, a BMS fault alarm relay, and Auto Switchover capabilities. It is designed for precise electronic temperature control of trace heating systems in commercial, residential, and non-residential applications.</p>
<p><b>Features</b></p>	<ul style="list-style-type: none"> <li>• Monitoring: Provides 24/7, year-round active monitoring of 2 independent heating circuits (duty/standby)</li> <li>• Soft-Start: Built-in feature eliminates inrush currents on Solco self-regulating heating cables, allowing substantially longer circuit lengths than standard controllers</li> <li>• Security: Front panel UP, DOWN, and ENTER buttons are locked during normal use to prevent inadvertent or unauthorized changes to programmed settings</li> <li>• User Interface:             <ul style="list-style-type: none"> <li>- 3 LED indicators for POWER, FAULT, and LOAD</li> <li>- Main 8x2 digit LCD screen alternating between live and set temperature readings every minute</li> </ul> </li> <li>• Entries: Guide markings for cable gland entry holes: 3xM20 for power and communications cables, 2xM20/M25 for heating cables</li> <li>• Plug &amp; Play: Pre-set to maintain 5°C for freeze protection; configurable for AIR (ambient) or LINE (pipe) sensing</li> <li>• Mounting: Can be installed using a Solco stainless steel pipe mount bracket</li> </ul>
<p><b>Technical Specification</b></p>	<p><b>Model:</b> Smart-PRO</p> <p><b>Supply voltage:</b> 100 Vac (min.) – 270 Vac (max.), 50 / 60 Hz</p> <p><b>Load current (max.):</b> 32 A (Max. Power 6600 W)</p> <p><b>Ambient operating temperature range:</b> -20°C to +60°C</p> <p><b>Temperature measurement range:</b> -50°C to +450°C</p> <p><b>Temperature setting range:</b> -45°C to +495°C</p> <p><b>Ingress Protection (IP)rating:</b> IP66 / 67</p> <p><b>Enclosure material, size:</b> Body and lid ABS – size 175 x 175 x 75 mm</p> <p><b>Mounting:</b> Brackets provided for wall / pipe mounting</p> <p><b>Terminals (WAGO lever type):</b> 9 x 4.0mm<sup>2</sup> max. conductor size (24 – 12AWG) 6 x 2.5mm<sup>2</sup> max. conductor size (24 – 14 AWG)</p> <p><b>Inputs:</b> 1 x mains supply</p> <p><b>Outputs:</b> 1 x factory wired PT100 temperature sensor 2 x heating circuits 2 x safety relay output, 240Vac max. 3.0A SPST 1 x TTL-RS232 comms output</p>
<p><b>Certification</b></p>	<p>CE UK CA</p>

## Installation Guide

The Smart-PRO can be mounted on a wall or pipe mount support bracket supplied by Solco. Simply undo the 4 screws in the lid to reveal through holes for mounting to the wall or bracket.

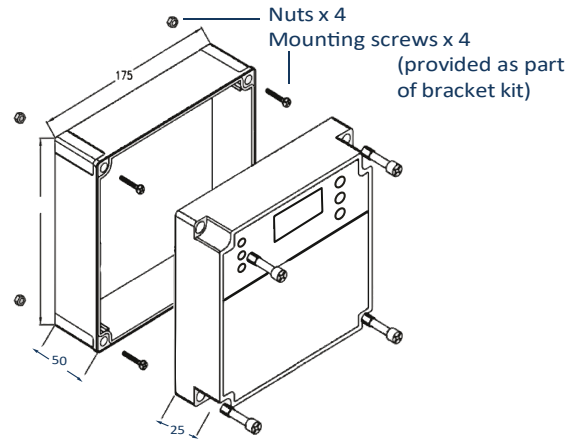

## Connection and controls

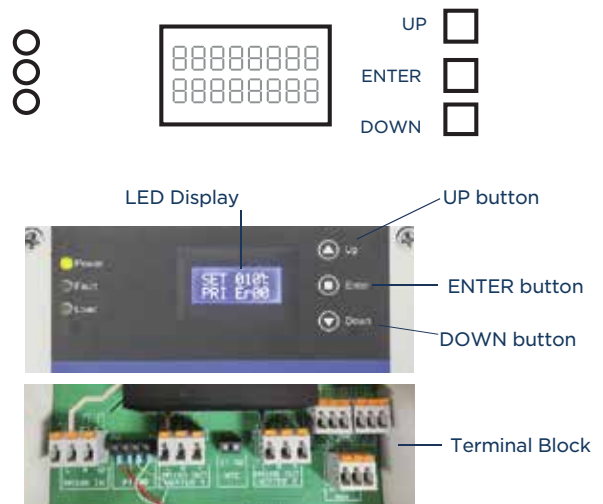

## Smart GUARD



# SP-MT-30

## Mechanical Temperature Controller

For commercial heating application



SOLCO Heating Solutions

<p><b>Description</b></p>	<p>The SP-MT-30 is a temperature controller with a built-in mechanical thermostat, specifically designed for frost protection of piping, snow melting on roofs, and efficient operation of stair and ramp electrical heating systems. The mechanical thermostat uses a capillary sensor exposed outside the enclosure to monitor temperature and control the heating system ON/OFF based on the set value, which can be adjusted manually via the dial. The durable plastic enclosure is engineered to meet the requirements of heating cable systems and provides IP66 ingress protection. The unit is fully compatible with SOLCO heating cable termination kits for easy installation.</p>																								
<p><b>Features</b></p>	<ul style="list-style-type: none"> <li>• Solco SP-MT-30 is a temperature control enclosure kit featuring a built-in mechanical temperature controller and signal lamps</li> <li>• Designed for freeze protection and temperature maintenance of pipelines, roofs, gutters, and various architectural applications</li> <li>• Monitors temperature via a sensor probe located outside the enclosure to maintain set temperature levels</li> <li>• Includes a 1.0m lead cable for line sensing</li> </ul>																								
<p><b>Technical Specification</b></p>	<table border="0"> <tr> <td><b>Models:</b></td> <td>SP-MT-30-1L/2L/1H/2H</td> </tr> <tr> <td><b>Rated Voltage 2L/2H:</b></td> <td>220-240Vac</td> </tr> <tr> <td><b>Rated Voltage 1L/1H:</b></td> <td>110-120Vac</td> </tr> <tr> <td><b>Max. Load Current:</b></td> <td>30A</td> </tr> <tr> <td><b>Temperature Setting Range 1L/2L:</b></td> <td>-30°C ~ +30°C</td> </tr> <tr> <td><b>Temperature Setting Range 1H/2H:</b></td> <td>0°C ~ +90°C</td> </tr> <tr> <td><b>Ambient Operating Temperature:</b></td> <td>-10°C ~ +50°C</td> </tr> <tr> <td><b>Temperature Sensor Type:</b></td> <td>Oil Type (Stainless steel probe)</td> </tr> <tr> <td><b>Enclosure Material:</b></td> <td>Polycarbonate</td> </tr> <tr> <td><b>Enclosure Dimensions:</b></td> <td>125mm x 175mm x 100mm</td> </tr> <tr> <td><b>No. of Terminal (Rated Cross Section):</b></td> <td>1 (6mm<sup>2</sup>)</td> </tr> <tr> <td><b>Control Method:</b></td> <td>ON / OFF</td> </tr> </table>	<b>Models:</b>	SP-MT-30-1L/2L/1H/2H	<b>Rated Voltage 2L/2H:</b>	220-240Vac	<b>Rated Voltage 1L/1H:</b>	110-120Vac	<b>Max. Load Current:</b>	30A	<b>Temperature Setting Range 1L/2L:</b>	-30°C ~ +30°C	<b>Temperature Setting Range 1H/2H:</b>	0°C ~ +90°C	<b>Ambient Operating Temperature:</b>	-10°C ~ +50°C	<b>Temperature Sensor Type:</b>	Oil Type (Stainless steel probe)	<b>Enclosure Material:</b>	Polycarbonate	<b>Enclosure Dimensions:</b>	125mm x 175mm x 100mm	<b>No. of Terminal (Rated Cross Section):</b>	1 (6mm <sup>2</sup> )	<b>Control Method:</b>	ON / OFF
<b>Models:</b>	SP-MT-30-1L/2L/1H/2H																								
<b>Rated Voltage 2L/2H:</b>	220-240Vac																								
<b>Rated Voltage 1L/1H:</b>	110-120Vac																								
<b>Max. Load Current:</b>	30A																								
<b>Temperature Setting Range 1L/2L:</b>	-30°C ~ +30°C																								
<b>Temperature Setting Range 1H/2H:</b>	0°C ~ +90°C																								
<b>Ambient Operating Temperature:</b>	-10°C ~ +50°C																								
<b>Temperature Sensor Type:</b>	Oil Type (Stainless steel probe)																								
<b>Enclosure Material:</b>	Polycarbonate																								
<b>Enclosure Dimensions:</b>	125mm x 175mm x 100mm																								
<b>No. of Terminal (Rated Cross Section):</b>	1 (6mm <sup>2</sup> )																								
<b>Control Method:</b>	ON / OFF																								
<p><b>Certification</b></p>	<p>CE UK CA</p>																								

### Installation Guide

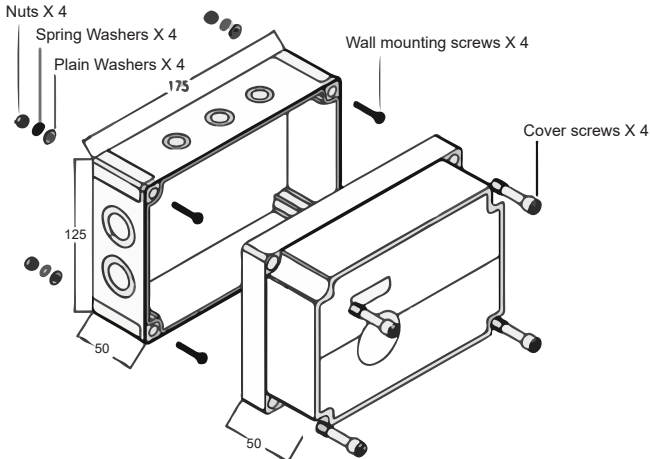

### Connection and controls

SP-MT-30-1L / 2L

SP-MT-30-1H / 2H

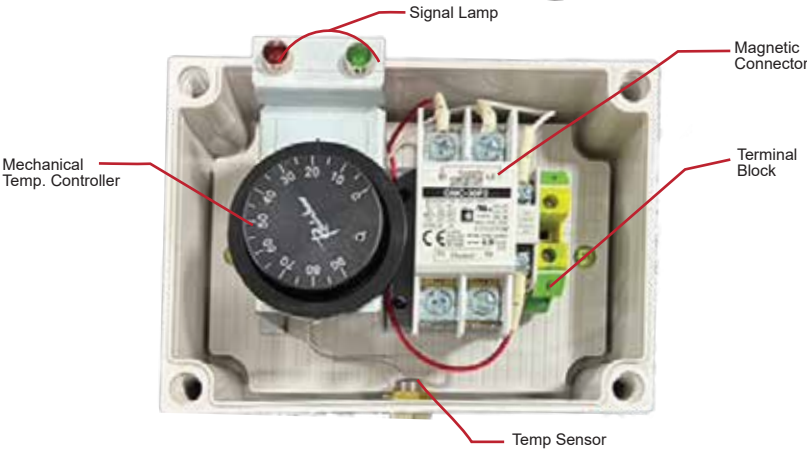

### SP-MT-30 Mechanical Temperature Controller



# ET-16

## Electronic Thermostat

for de-icing systems with water-tight plastic enclosure IP67



<p><b>Description</b></p>	<p>The Solco ET-16 is an electronic thermostat enclosure kit, engineered for optimal performance of electrical heating systems. It is ideal for pathways, steps, and ramps to prevent ice formation, as well as for roof heating systems to avoid ice buildup in drainage system components.</p>																										
<p><b>Features</b></p>	<ul style="list-style-type: none"> <li>• Switches a built-in 16A, 250V relay when ambient temperature is within the specified range; relay contacts open when temperature falls outside the set range</li> <li>• Example: Heating is blocked when temperature exceeds +5°C or drops below -15°C, as ice formation is unlikely outside this range</li> <li>• Rugged plastic enclosure designed for trace heating systems, including harsh locations</li> <li>• Body and cover constructed from fiberglass-reinforced polyamide for high thermal endurance and mechanical strength</li> <li>• Conductive carbon black added to reduce surface resistivity to &lt;math&gt;&lt;10^9\Omega\cdot\text{cm}&lt;/math&gt;</li> <li>• Water-tight IP67 protection provided by a silicone rubber gasket and captive steel lid screw</li> </ul>																										
<p><b>Technical Specification</b></p>	<table border="0"> <tr> <td><b>Model:</b></td> <td>ET-16</td> </tr> <tr> <td><b>Supply voltage:</b></td> <td>220Vac 50Hz</td> </tr> <tr> <td><b>Max. load current:</b></td> <td>16A</td> </tr> <tr> <td><b>Operating temperature:</b></td> <td>+5°C to +45°C</td> </tr> <tr> <td><b>Temperature range of actuating signal output:</b></td> <td>-15°C to +5°C</td> </tr> <tr> <td><b>Lower limit setting available:</b></td> <td>-15°C to 0°C</td> </tr> <tr> <td><b>Rated power consumption:</b></td> <td>0.5W max.</td> </tr> <tr> <td><b>Temperature sensor:</b></td> <td>NTC 1.0 kohm@25°C</td> </tr> <tr> <td><b>Type of Protection:</b></td> <td>IP67 according to EN60529</td> </tr> <tr> <td><b>Enclosure Material:</b></td> <td>Fiberglass reinforced polyamide with graphite halogen-free, UV stablized, graphite black</td> </tr> <tr> <td><b>Overall dimensions:</b></td> <td>120mm x 120mm x 90mm</td> </tr> <tr> <td><b>Plastic cable gland:</b></td> <td>Fiberglass reinforced nylon 1" Thread</td> </tr> <tr> <td><b>Gasket and seal:</b></td> <td>Flame-proof silicone rubber</td> </tr> </table>	<b>Model:</b>	ET-16	<b>Supply voltage:</b>	220Vac 50Hz	<b>Max. load current:</b>	16A	<b>Operating temperature:</b>	+5°C to +45°C	<b>Temperature range of actuating signal output:</b>	-15°C to +5°C	<b>Lower limit setting available:</b>	-15°C to 0°C	<b>Rated power consumption:</b>	0.5W max.	<b>Temperature sensor:</b>	NTC 1.0 kohm@25°C	<b>Type of Protection:</b>	IP67 according to EN60529	<b>Enclosure Material:</b>	Fiberglass reinforced polyamide with graphite halogen-free, UV stablized, graphite black	<b>Overall dimensions:</b>	120mm x 120mm x 90mm	<b>Plastic cable gland:</b>	Fiberglass reinforced nylon 1" Thread	<b>Gasket and seal:</b>	Flame-proof silicone rubber
<b>Model:</b>	ET-16																										
<b>Supply voltage:</b>	220Vac 50Hz																										
<b>Max. load current:</b>	16A																										
<b>Operating temperature:</b>	+5°C to +45°C																										
<b>Temperature range of actuating signal output:</b>	-15°C to +5°C																										
<b>Lower limit setting available:</b>	-15°C to 0°C																										
<b>Rated power consumption:</b>	0.5W max.																										
<b>Temperature sensor:</b>	NTC 1.0 kohm@25°C																										
<b>Type of Protection:</b>	IP67 according to EN60529																										
<b>Enclosure Material:</b>	Fiberglass reinforced polyamide with graphite halogen-free, UV stablized, graphite black																										
<b>Overall dimensions:</b>	120mm x 120mm x 90mm																										
<b>Plastic cable gland:</b>	Fiberglass reinforced nylon 1" Thread																										
<b>Gasket and seal:</b>	Flame-proof silicone rubber																										
<p><b>Certification</b></p>	<p>CE UK CA</p>																										

### Installation Guide

The Solco ET-16 is an electronic thermostat enclosure kit, specifically designed to optimize the performance of electrical heating systems. It is suitable for pathways, steps, and ramps to prevent ice formation, as well as for roof heating systems to protect drainage system components from damage caused by ice.

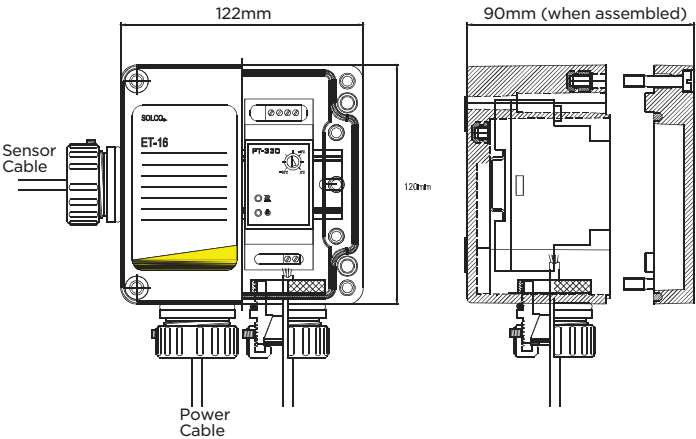

### Connection and controls

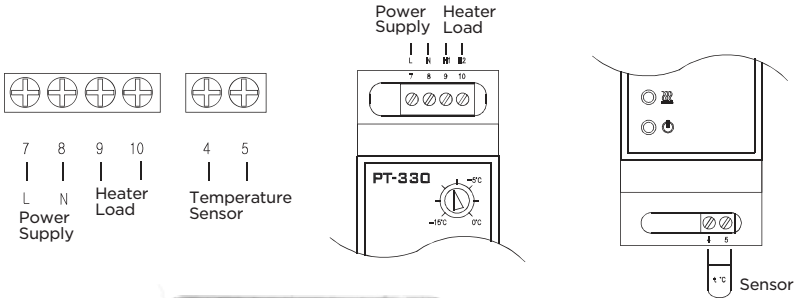

### SP-MT-30 Mechanical Temperature Controller



# Connection Accessories

SP-HPEK / SP-HPK

SP-CPEK / SP-CPK, SP-CEK

SP-PTK-S

SP-ETK-S

SP-PTK-M

SP-ETK-M

SP-JBL

SP-3JB

SP-2JB

SP-IEK

SP-BRP-001/002/003/004

SP-GCT

SP-AFT-45

# 03





# Connection Accessories

# SP-HPEK

## SP-HPK

### Termination Kits



#### Description

The SP-HPEK and SP-HPK are heat-shrink power and end termination kits, designed for the entry of Solco heating cables into thermostats, controllers, junction boxes, and for remote end termination, ensuring safe and reliable connections.

#### Features

- Manufacturer-approved termination method for Solco heating cables, ensuring reliability and compliance
- Flexible kit configurations available for various applications:
  - Power termination and enclosure entry
  - Remote cable end termination
  - SP-HPEK Kit: Terminates both ends of a single cable
  - SP-HPK Kit: Single-cable termination with secure entry into an enclosure, junction box, or temperature controller
  - TEE Configurations: Require 3 kits for proper termination
  - SPLICE Configurations: Require 2 kits for proper termination
- Provides safe, simple, and approved solutions for all Solco heating cable installations

#### Technical Specification

##### a. SP-HPEK

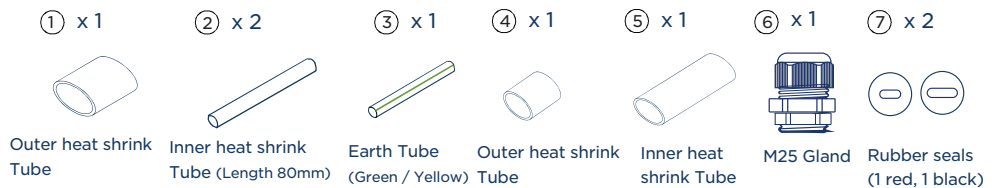

##### b. SP-HPK

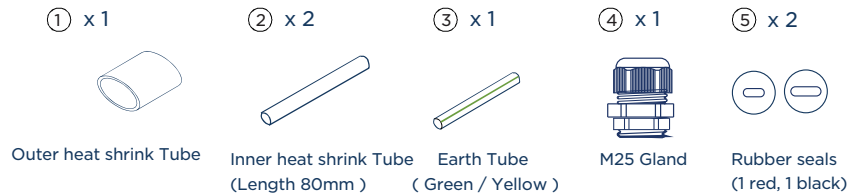

#### Certification



# SP-CPEK

## SP-CPK, SP-CEK

### Termination Kits



#### Description

The SP-CPEK, SP-CPK, and SP-CEK are cold silicon rubber boot power and end termination kits, designed for the entry of Solco heating cables into thermostats, controllers, and junction boxes, as well as for remote end termination, providing safe and reliable connections.

#### Features

- Manufacturer-approved termination method for Solco heating cables, ensuring reliability and compliance
- Flexible kit configurations available for various applications:
  - Power termination and enclosure entry
  - Remote cable end termination
  - SP-CPEK Kit: Terminates both ends of a single cable
  - SP-CPK Kit: Single-cable termination with secure entry into an enclosure, junction box, or temperature controller
  - SP-CEK Kit: Remote end termination for cables located away from the power supply
  - TEE Configurations: Require 3 kits for proper termination
  - SPLICE Configurations: Require 2 kits for proper termination
- Provides safe, simple, and approved solutions for all Solco heating cable installations

#### Technical Specification

##### a. SP-CPEK

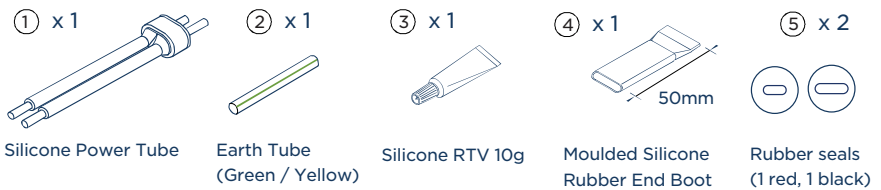

##### b. SP-CPK

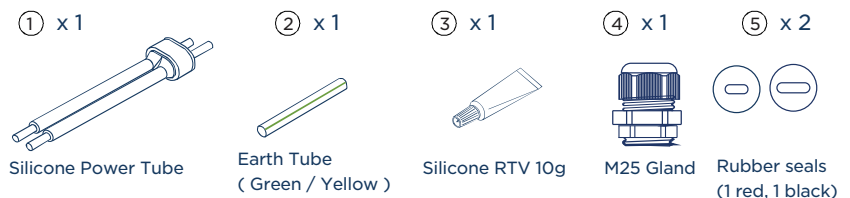

##### c. SP-CEK

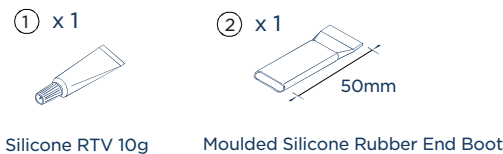





#### Certification

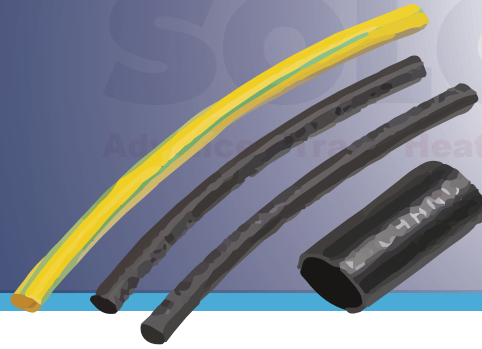

# SP-PTK-S

## Power Termination Kit





<p><b>Description</b></p>	<p>The SP-PTK-S is a power termination kit designed for connecting Solco parallel heating cables to the power supply inside enclosures, ensuring safe and compliant electrical connections.</p>								
<p><b>Features</b></p>	<ul style="list-style-type: none"> <li>• Enables power termination of Solco parallel trace heating cables for safe and reliable connection to the power supply</li> <li>• Uses easy-to-apply heat-shrinkable tubing with adhesive, forming a semi-flexible, moisture-proof encapsulation when heated</li> <li>• Low-profile design allows the finished termination to be installed inside junction boxes / enclosures</li> </ul>								
<p><b>Technical Specification</b></p>	<div style="text-align: center;"> <p>① x 1</p>  <p>Outer Heat Shrink Tubing (length 30mm)</p> </div> <div style="display: flex; justify-content: space-around; margin-top: 20px;"> <div style="text-align: center;"> <p>② x 2</p>  <p>Inner Heat Shrink Tubing (length 80mm)</p> </div> <div style="text-align: center;"> <p>③ x 1</p>  <p>Earth Tube(Green / Yellow, (length 100mm)</p> </div> </div> <div style="margin-top: 20px;"> <table border="0" style="width: 100%;"> <tr> <td style="width: 50%;">Ingress Protection :</td> <td style="width: 50%;">IP66</td> </tr> <tr> <td>Min. Ambient Temperature :</td> <td>-50°C</td> </tr> <tr> <td>Max. Exposure Temperature:</td> <td>135°C</td> </tr> <tr> <td>Construction Material :</td> <td>Polymeric</td> </tr> </table> </div>	Ingress Protection :	IP66	Min. Ambient Temperature :	-50°C	Max. Exposure Temperature:	135°C	Construction Material :	Polymeric
Ingress Protection :	IP66								
Min. Ambient Temperature :	-50°C								
Max. Exposure Temperature:	135°C								
Construction Material :	Polymeric								
<p><b>Certification</b></p>	<p>CE UK CA</p>								

# SP-ETK-S

## End Termination Kit





<b>Description</b>	<p>The SP-ETK-S is an end termination kit designed for safely terminating Solco parallel heating cables at the end of a circuit, providing safe and reliable cable end connections.</p>		
<b>Features</b>	<ul style="list-style-type: none"> <li>• Enables end termination of Solco parallel trace heating cables</li> <li>• Uses easy-to-apply heat-shrinkable tubing with adhesive, forming a semi-flexible, moisture-proof encapsulation when heated</li> <li>• Low-profile design allows the finished termination to be installed directly on the pipe</li> </ul>		
<b>Technical Specification</b>	<p>① x 1</p>  <p>Adhesive Heat Shrink (length 50mm)</p>	<p>② x 2</p>  <p>Adhesive Heat Shrink (length 20mm)</p>	<p>③ x 1</p>  <p>Barrel Crimp (for braided cable only)</p>
<b>Certification</b>	<p>CE UK CA</p>		

# SP-PTK-M

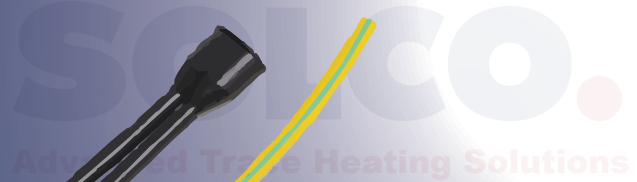
## Cold Silicon Termination Kit

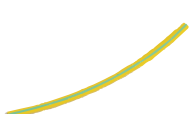



<p><b>Description</b></p>	<p>The SP-PTK-M is a cold silicon power termination kit designed for connecting Solco parallel heating cables to the power supply inside enclosures, ensuring safe and compliant electrical connections</p>	
<p><b>Features</b></p>	<ul style="list-style-type: none"> <li>• Designed for terminating all Solco parallel trace heating cables into a junction box while maintaining electrical insulation of the cable conductors and core</li> <li>• Features a silicone-molded power tube that eliminates the need for a heat gun or torch, providing safe insulation of the heating core</li> <li>• No hot work permit is required for installation, simplifying and accelerating the installation process</li> </ul>	
<p><b>Technical Specification</b></p>	<p>① x 1</p>  <p>Silicone Power Tube (Black) including two transparent guide tubes (PFA) and insert guard (Nylon)</p>	
	<p>② x 1</p>  <p>Earth Tube ( Green / Yellow )</p>	<p>③ x 1</p>  <p>Silicone Rubber RTV paste 10g (sold seperately)</p>
	<p>Ingress Protection : Min. Ambient Temperature : Max. Exposure Temperature : Construction Material :</p>	<p>IP66 -50°C 240°C Silicone Rubber</p>
<p><b>Certification</b></p>		

# SP-ETK-M

## Cold Silicon Termination Kit



<p><b>Description</b></p>	<p>The SP-ETK-M is a cold silicon end termination kit designed for terminating Solco parallel heating cables at the end of a circuit, providing safe and reliable cable end connections.</p>		
<p><b>Features</b></p>	<ul style="list-style-type: none"> <li>• Enables end-termination of Solco parallel trace heating cables</li> <li>• Suitable for applications with temperature ratings from -50°C to 240°C</li> <li>• Provides excellent electrical insulation protection for the cable conductors and core</li> <li>• Does not require a heat gun or torch for installation, eliminating the need for a hot work permit</li> </ul>		
<p><b>Technical Specification</b></p>	<p>① x 1</p>  <p>Moulded Silicone Rubber End Boot</p>	<p>② x 1</p>  <p>Silicone Rubber RTV paste 10g (sold separately)</p>	<p>③ x 1</p>  <p>Barrel Crimp (for braided cable only)</p>
<p><b>Certification</b></p>			

# SP-JBL

## Large Junction Box



<b>Description</b>	<p>The SP-JBL is a professional quality 4-way junction box designed to easily accommodate power and/or heating cable entry and connection. There are enough terminals for 1 x power and 3 x heater circuits. The enclosure is made from tough weather proof ABS, with added UV inhibitor, making it suitable for outdoor and indoor environments. Typical application/use is to connect POWER to or TEE/SPLICE up to 3 heating Cables.</p>
<b>Features</b>	<ul style="list-style-type: none"> <li>• Tough UV resistant ABS enclosure</li> <li>• IP66/67 rated</li> <li>• PCB mounted lever type terminals</li> </ul>
<b>Technical Specification</b>	<p><b>Enclosure</b></p> <p><b>Dimensions:</b> Width: 125 mm, Height: 125 mm, Depth: 75 mm Inner depth: 60.5 mm, Outer base depth: 50 mm Outer cover height: 25 mm</p> <p><b>Body material:</b> Base ABS and UV resistance additive Cover: ABS and UV resistance additive, Gasket: polyurethane</p> <p><b>Knockouts:</b> 8 x M25, M20 pilot holes 2 per each face</p> <p><b>IP rating:</b> 66/67</p> <p><b>Impact strength:</b> IK 08</p> <p><b>Minimum temperature rating (°C):</b> -40</p> <p><b>Maximum temperature rating (°C):</b> 80</p> <p><b>Short-term temperature range (°C):</b> -40 to 120</p> <p><b>Suitable for outdoor set-up:</b> Yes</p> <p><b>Wall fastening possible:</b> Yes</p> <p><b>Terminals: Rated voltage:</b> 1,000V</p> <p><b>Rated current:</b> 32A</p> <p><b>Cross section:</b> 6mm<sup>2</sup></p> <p><b>Assembly:</b> 1 in 'L', 3 out 'L1, L2, L3' 1 in 'N', 3 out 'N1, N2, N3' 1 in 'E', 3 out 'E1, E2, E3' PCB Mounted lever type</p>
<b>Certification</b>	

# SP-3JB

## Connectabox



### Description

The SP-3JB is a professional-quality T-shaped junction box designed for easy entry and connection of power and heating cables. It includes an internal terminal block with clearly marked wiring orientation. The terminals accommodate either 1 power to 2 heating circuits (SPLICE) or 1 heating circuit to 2 heating circuits (TEE) connections. The enclosure is constructed from durable, weatherproof PA66/TPE, offering superior UV resistance compared to ABS, and allows easy wiring insertion. Typical applications include connecting power or splicing/teeing heating circuits efficiently and safely.

### Features

- Durable, weatherproof enclosure with IP65 rating
- Enables easy and quick installation of Solco trace heating cables
- Versatile design supports power, end, splice, TEE, or elbow connections
- Compatible pipe mounting bracket kit available separately

### Technical Specification

**Cable entries :** 3

**Body material :** PA66 / SEBS / TPE

**IP rating :** 65

**Minimum temperature rating (°C) :** -40

**Maximum temperature rating (°C) :** 125

**Cable termination system :** 3 x 3 terminals, 32A, 450V.

**Comments :** This product comprises junction box,  
2 lid screws, terminal block, 3 cable glands &  
6 cable sealing EPDM grommets

### Certification



# SP-2JB

## Connectatube













**SOLCO.**  
Advanced Trace Heating Solutions

<b>Description</b>	<p>The SP-2JB is a professional-quality M25 tubular junction box designed for easy entry and connection of power and heating cables. It includes an internal terminal block with clearly marked wiring orientation. The terminals accommodate either 1 power to 1 heating circuit or 1 heating circuit to 1 heating circuit (splice) connections. The enclosure is made from durable, weatherproof PA66/TPE, offering superior UV resistance compared to ABS and allowing easy wiring insertion. Typical applications include connecting power to or splicing a heating circuit safely and efficiently.</p>
<b>Features</b>	<ul style="list-style-type: none"> <li>• Durable, weatherproof enclosure with IP68 rating</li> <li>• Enables easy and quick installation of Solco trace heating cables</li> <li>• Versatile design supports power, end, and splice connections</li> </ul>
<b>Technical Specification</b>	<p><b>Cable entries :</b> 2</p> <p><b>Body material :</b> PA66 / TPE</p> <p><b>IP rating :</b> 68</p> <p><b>Minimum temperature rating (°C) :</b> -40</p> <p><b>Maximum temperature rating (°C) :</b> 125</p> <p><b>Cable termination system :</b> 3 pole terminals, 32A, 450V.</p> <p><b>Comments :</b> This product comprises junction box, terminal block and 2 cable glands &amp; 4 cable sealing EPDM grommets</p>
<b>Certification</b>	

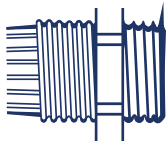
# SP-IEK

## Insulation Entry Kit

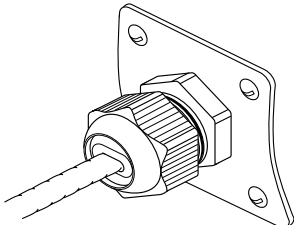

<p><b>Description</b></p>	<p>The SP-IEK is an insulation entry kit designed for use with Solco self-regulating heating cables and power cables with diameters ranging from 7mm to 13.5mm, ensuring safe and reliable cable entry.</p>	
<p><b>Compatible products</b></p>	<p style="text-align: center;"></p> <p>Applicable cables: HSR 10, 16, 24 VSR 16, 24, 30, 40 IPSR</p>	<p style="text-align: center;"></p> <p>Applicable cables: HSR 30 VSR 50 HWS-R/HWS-P MSR IPSR(e)</p>
<p><b>Technical Specification</b></p>	<div style="display: flex; justify-content: space-around; align-items: center;">    </div> <p>M25 gland body, cap and lock nut</p> <div style="text-align: center; margin: 20px 0;">  </div> <p>Heating cable sealing grommets</p> <div style="display: flex; justify-content: space-around; align-items: center; margin: 20px 0;">   </div> <p>Power cable sealing grommet Minimum cable diameter - 7mm Maximum cable diameter - 13.5mm</p> <p>Metal plate : stainless steel, 316L</p> <div style="text-align: right; margin-top: 20px;">  </div>	
<p><b>Certification</b></p>	<p style="text-align: center;"></p>	

# SP-BRP

## Bracket Kit



**SOLCO**  
Advanced Trace Heating Solutions

### Description

This 304 stainless steel bracket kit is designed for mounting Solco controllers and accessories onto horizontal or vertical pipes using a quick-release band. The kit includes all necessary nuts and bolts for securely fixing the mounted products.

### Compatible products

Product	Top Plate	Description
SMART-ECO	SP-001	Electronic temperature controller/thermostat
SP-MT-30	SP-001	Mechanical thermostat
SP-JBL	SP-001/SP-002	Junction box large
SP-JBS	SP-001/SP-002	Junction box small
Smart-IND/ Smart-PRO	SP-003	Electronic temperature controller/thermostat
SP-3JB / SP-2JB	SP-004	3-way connectabox / 2-way connectabox

### Technical Specification

#### Leg Upstand

Height	140mm
Width	30mm
Depth	30mm
Thickness	1.0mm

#### Top Plate

	SP-001	SP-002	SP-003	SP-004
Height	125mm	125mm	175mm	70mm
Width	175mm	125mm	175mm	75mm
Depth	N/A	N/A	N/A	N/A
Thickness	1.0mm	1.0mm	1.0mm	1.0mm

### Certification



# SP-GCT

## Glass Fibre Cloth Tape



### Description

This glass fibre cloth tape is manufactured from electrical grade material with a durable acrylic / silicon adhesive. Offering excellent solvent and flagging resistance for high temperature applications

### Features

- Tough abrasive resistance
- Excellent mechanical and electrical properties
- High conformable, no corrosion, resisting tear from edge
- Flame retardant
- High tensile strength

### Technical Specification

	SP-GCTF-50	SP-GCTH-50
<b>Adhesive:</b>	Acrylic (FR)	Silicone
<b>Width:</b>	12mm (others available)	12mm (others available)
<b>Standard Length:</b>	50m (others available)	33m (others available)
<b>Total Thickness:</b>	190µm (0.190mm)	180µm (0.180mm)
<b>Tensile Strength:</b>	5.28 N / cm	3.92 N / cm
<b>Elongation:</b>	7% min.	9% min.
<b>Dielectric strength:</b>	2.5kV	4kV
<b>Steel Adhesion:</b>	3.0 N / cm	3.0 N / cm
<b>Application</b>		
<b>Temperature:</b>	-29°C to +177°C.	-73°C to +260°C.
<b>Insulation Class:</b>	F	H

### Certification



# SP-AFT-45

## Micro Adhesive Aluminium Foil Tape

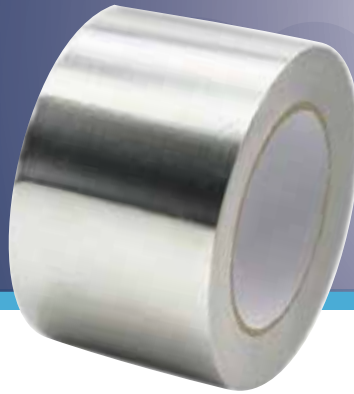

SOLCO  
Space Heating Solutions

<p><b>Description</b></p>	<p>This soft aluminium foil tape features a long-lasting, UV-resistant acrylic adhesive on one side and is lined with release paper to protect the adhesive surface. The product has been tested to BS476 Part 6 &amp; 7 standards and complies with Class 1 and Class 0 fire regulations.</p>
<p><b>Features</b></p>	<ul style="list-style-type: none"> <li>• High-performance aluminium foil tape designed for applications requiring long service life, strong adhesion, and UV resistance</li> <li>• Surfaces must be clean, dry, and free from dust before application</li> <li>• If needed, clean surfaces sparingly with a ketone-free proprietary solvent and allow to dry prior to applying the tape</li> </ul>
<p><b>Technical Specification</b></p>	<p><b>Width :</b> 48mm (others available)  <b>Standard Length :</b> 45m (others available)  <b>Total Thickness :</b> 120µm (incl. release liner)  <b>Shear :</b> &gt; 200 hours  <b>Tensile Strength :</b> 95.5N / 25mm  <b>Elongation :</b> 5%  <b>Peel Adhesion :</b> 20 mins 14.5 N / 25mm                                    60 mins 14.3 N / 25mm                                    24 hours 19.4 N / 25mm  <b>Looptack :</b> 12.0 N  <b>Humidity Shear test :</b> &gt; 4 hours  <b>Application Temperature :</b> -20°C to +50°C            (The surface must be free from ice or moisture).  <b>Service Temperature :</b> -40°C to + 120°C            (Can withstand 140°C for a few minutes).  <b>Moisture Vapour Permeability :</b> Less than 1gm/M2 /24 hrs @ 38°C &amp; 90% RH</p>
<p><b>Certification</b></p>	<p>CE UK CA</p>

# SOLCO.

Advanced Trace Heating Solutions



A low-angle, upward-looking photograph of an industrial facility. The scene is dominated by a complex network of large, silver-colored metal pipes and ductwork. Some pipes are wrapped in insulation. A prominent feature is a large, perforated metal walkway or platform that spans across the upper part of the frame. The ceiling consists of a series of parallel metal beams. The lighting is bright and even, highlighting the metallic surfaces and the intricate layout of the infrastructure.

**SOLCO.**

**Advanced Trace Heating Solutions**